

Congratulations, you have purchased the finest exhaust system available for your motorcycle. Your Vance & Hines exhaust is designed and crafted for performance, quality, and style. Please follow the instructions below, check exhaust system for missing or damaged parts and if you need any assistance please contact our technical support line (562) 921-7461.

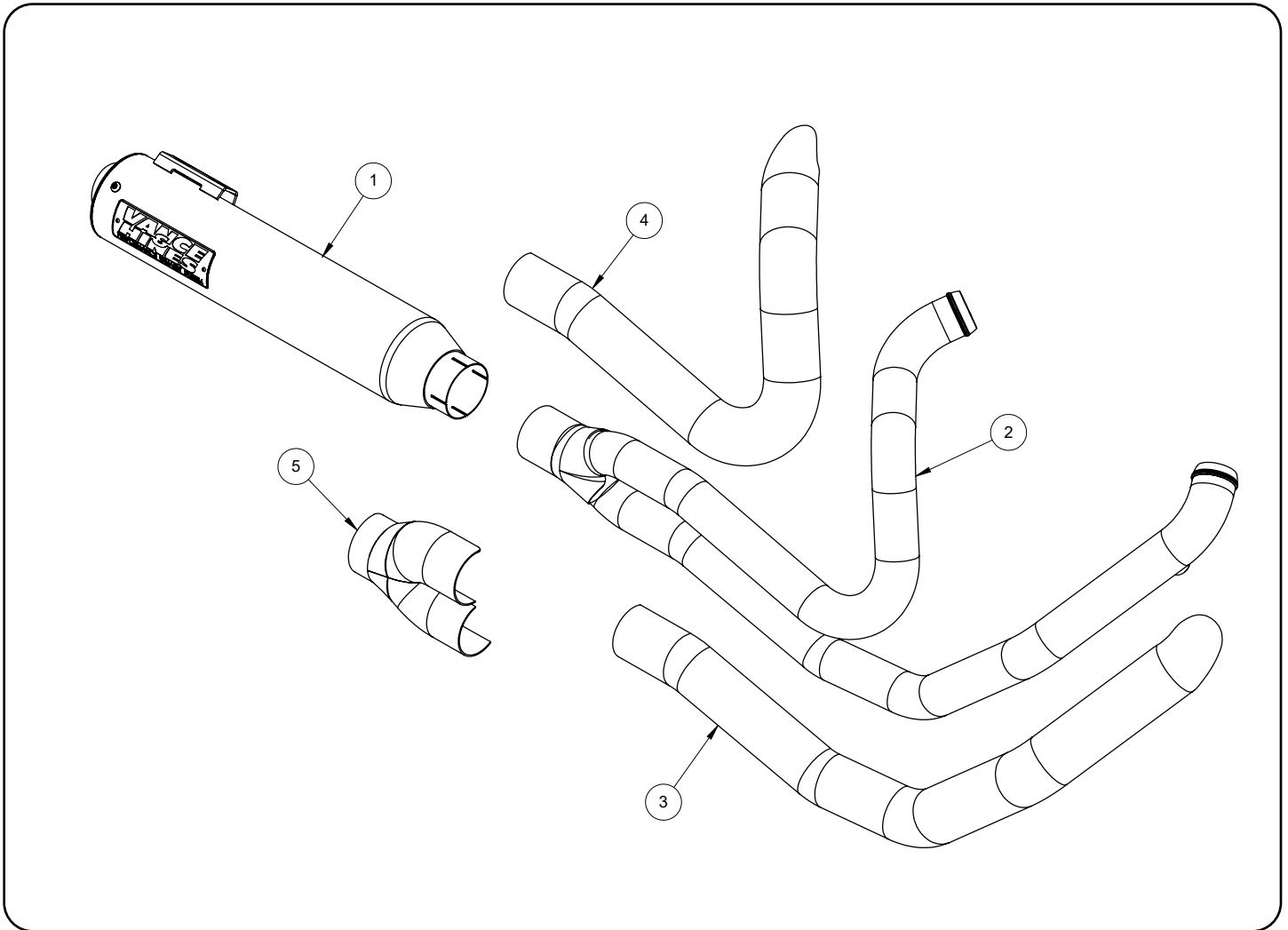

PARTS LIST

NO.	PART #	Description	NO.	PART #	Description	Qty
1	D445RC-S/D338RB-S/D339RP-S	MUFFLER CAN ASSY	11	A286HW	3/8" SPLIT LOCK WASHER	2
2	D1145FC/D1138FB/D1338FP	HEADER ASSEMBLY	12	A672HW	R FLOOR BOARD SPACER	1
3	D1144HC/D1138HB/D1338HP	FRONT HEAT SHIELD	13	A471HW	F FLOOR BOARD SPACER	1
4	D1145HCD1139HB/D1339HP	REAR HEAT SHIELD	14	A470HW	3/8"-16 X 1.75" SHCS	1
5	D1146HC/D137HB/D337HP	COLLECTOR SHIELD	15	A102HW	3/8"-16 X 3.00" SHCS	1
6	A240HW	5/16"-18 X 5/8IN FHS	16	A197HW	SINGLE NUT PLATE	1
7	A195HW	DOGBONE NUT PLATE	17	181-P	HEADER BRACKET	1
8	A644ST	18-12MM O2 ADAPTOR	18	1174-P	MUFFLER BRACKET	1
9	A966HW	2.625" BAND CLAMP	19	A435HW	5/16-18 X 5/8IN BHCS	2
10	A268HW	1.00-2.00 HOSE CLAMP				

HARDWARE

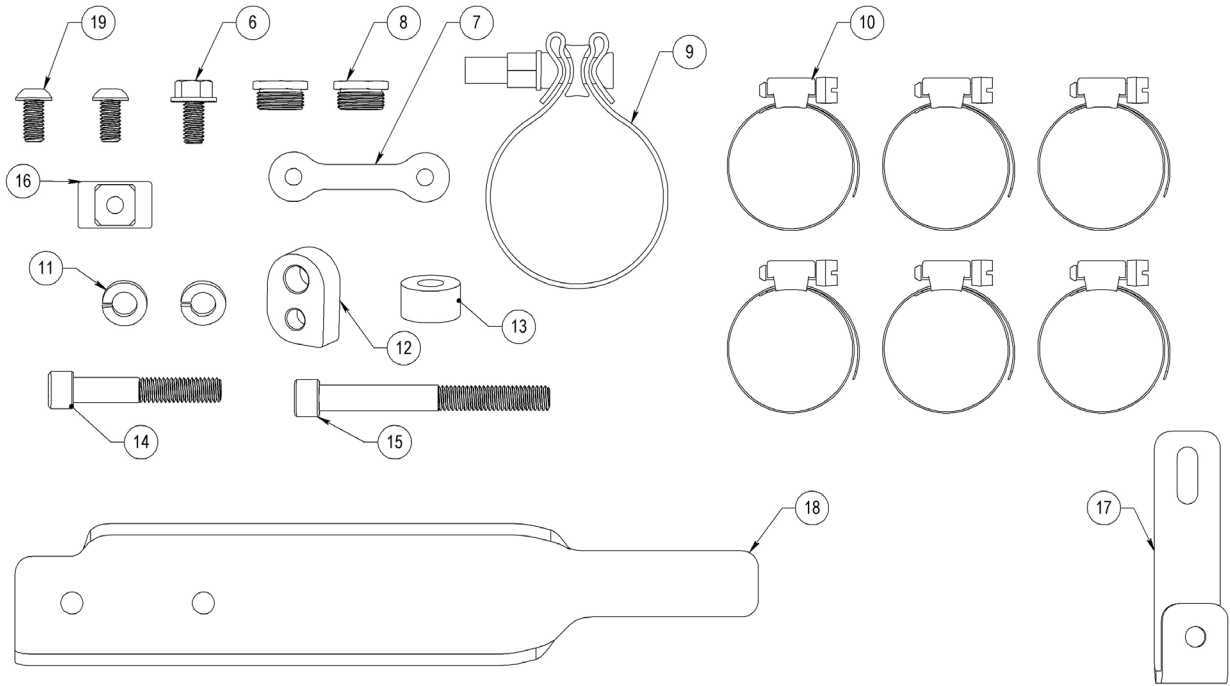

TOOLS REQUIRED

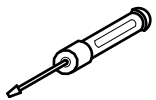

Flat Head Screwdriver

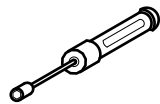

5/16 Nut Driver

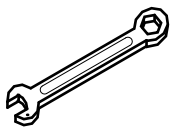

Combination Wrenches:
1/2", 9/16", 14mm,
17mm, 19mm

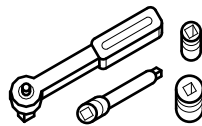

3/8" Drive Ratchet w/ 4" extension
1/2", 9/16", 15mm, 16mm Deep Sockets
19mm Socket

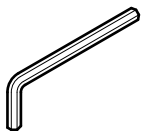

Allen Wrenches:
3/16", 5/16"

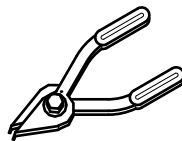

Snap Ring Pliers

STOCK EXHAUST SYSTEM REMOVAL

- 1.** Remove both left and right saddlebags and set them aside. Remove the right side panel.
- 2.** Loosen the pinch clamp bolt on the front end of muffler(s).
- 3.** Remove the two bolts and washers that mount the muffler(s) to the saddlebag supports.
- 4.** Remove the stock muffler(s) and set aside. NOTE: It may be necessary to use a penetrating lubricant to loosen muffler(s) from the head pipe.
- 5.** Locate and unplug the O2 sensor wires from the wiring harness (Grey and Black connectors located behind right side panel) and remove cable ties holding wires to frame. Feed the end of the wires through the frame so they are free from the motorcycle. NOTE: Pay attention to wire routing for re-installation.
- 6.** Remove the right side floor board.
- 7.** Remove the right side passenger floor board. (If equipped)
- 8.** Loosen head pipe clamp connecting the left side muffler to the rear crossover header and the mount bracket on the backside of the oil pan. Remove the crossover section from the head pipe and the head pipe clamp.
- 9.** Remove the mount clamp located behind the oil pan. The mount and bolts will not be re-used.
- 10.** Remove nut from front headpipe mounting bracket and stud located to the right of the transmission cover.
- 11.** Loosen the heat shield clamps on both front and rear exhaust pipes.
- 12.** Remove the two flange mounting nuts from each head pipe, located at the cylinder head. Carefully remove the head pipes and set aside.
- 13.** Carefully remove the O2 sensors from the stock head pipes and save for re-use with the new system.
- 14.** Carefully remove the exhaust port flanges and circlips from the stock exhaust system using snapping pliers. NOTE: If circlips look bent or twisted, replace them.

VANCE & HINES EXHAUST INSTALLATION

NOTE: Use appropriate Harley-Davidson service manual procedures when referring to exhaust installation.

1. Install **181-P** bracket onto the engine using the OEM mounting stud and nut (**Figure 1**). **NOTE:** Hand tighten only at this time.
2. Remove head pipes from their protective packaging. Place head pipes on a non-abrasive surface such as a blanket or carpet.
3. Install circlips and flanges from the stock system onto both the new head pipes.
4. Lay the header assembly into heat shields and loosely install 7 of the hose clamps into the mounting clips. Screw heads should be accessible when the system is installed on the motorcycle for adjustment purposes (**Figure 5**).
5. Apply a small amount of anti-seize compound to the threads of the O2 sensors and install them into the new head pipe. Install supplied 18mm to 12mm oxygen sensor adapter then install 12mm oxygen sensors.
6. Install the header assembly onto the engine using the stock flange nuts, finger tighten only at this time (**Figure 2**).
7. Connect the header assembly to the mounting bracket using A197HW single nut plate and A240HW 5/16-18 flange head bolt. Finger tighten only (**Figure 3**).
8. Slide the 1174-P muffler mounting bracket into the rear OEM rubber muffler mount. **NOTE:** Check Orientation of 1174-P as per (**Figure 4**). Apply a small amount of silicon grease to aid in installation.
9. Slide the muffler band clamp onto the muffler inlet and then install the muffler onto the headpipe collector. **The open end of the clamp should face the centerline of the motorcycle and the nut should be facing downward (Figure 5).**
10. Attach the muffler to the rear mounting bracket using A195HW dog bone nut plate and 2x A435HW button head bolts. Finger tighten only at this time.
11. Install the collector heat shield onto the header by sliding it on from the rear (**Figure 6**). Attach collector heat shield with the remaining two hose clamps. Finger tighten only at this time. **NOTE:** A soft mallet may be needed to seat the heat shield over the head pipes.
12. Tighten the exhaust port flange nuts, then tighten the muffler band clamp. Tighten the header mounting bolts and the rear muffler mount bolts.
13. Route the front O2 sensor wire along OE path and plug into the Grey connector. Route the rear O2 sensor along top of the transmission along the OE path and plug into the Black connector.
14. Tighten hose clamps securing header heat shields and collector heat shields making sure that they are aligned.
15. Install 3/8" lock washers (A286HW) on both 3/8"-16 (1.75" & 3.00" long) socket cap screws (supplied). Using these bolts reinstall the floor board with two machined spacers (supplied) on the forward mount (A471HW) and back mount (A672HW). (**Figure 7**)
NOTE: Machined spacers are located between the floor board supports and floor board mounting plate.
16. Re-install the right side passenger floor board, right side panel, then saddlebags.
17. Be sure to tighten all hardware before starting your motorcycle.
18. After installation and before starting the motorcycle, completely clean pipes and muffler with cleaning solvent and a clean soft cloth that will not leave residue. **NOTE:**

FIGURE 1



FIGURE 2



FIGURE 3

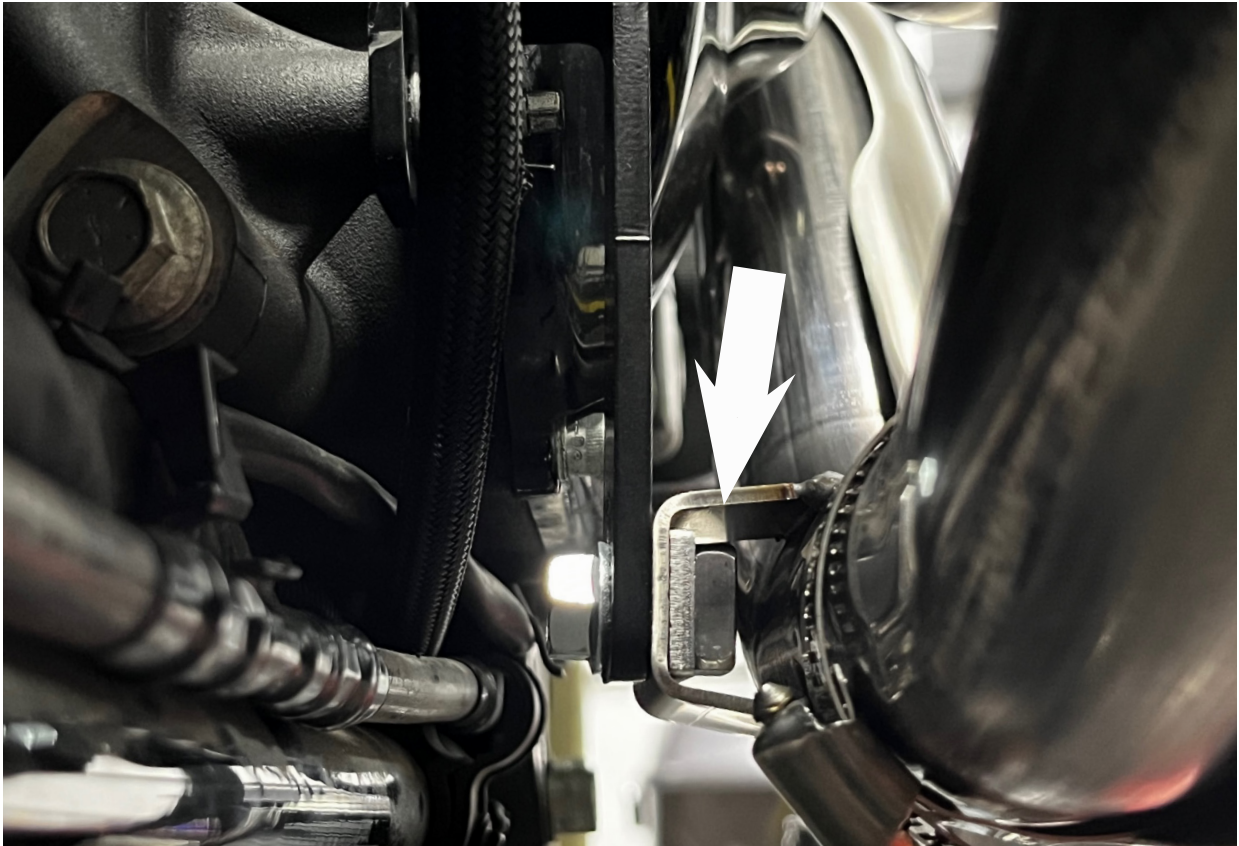

FIGURE 4

NOTE: 1174-P BEND POINTS TO GROUND



FIGURE 5

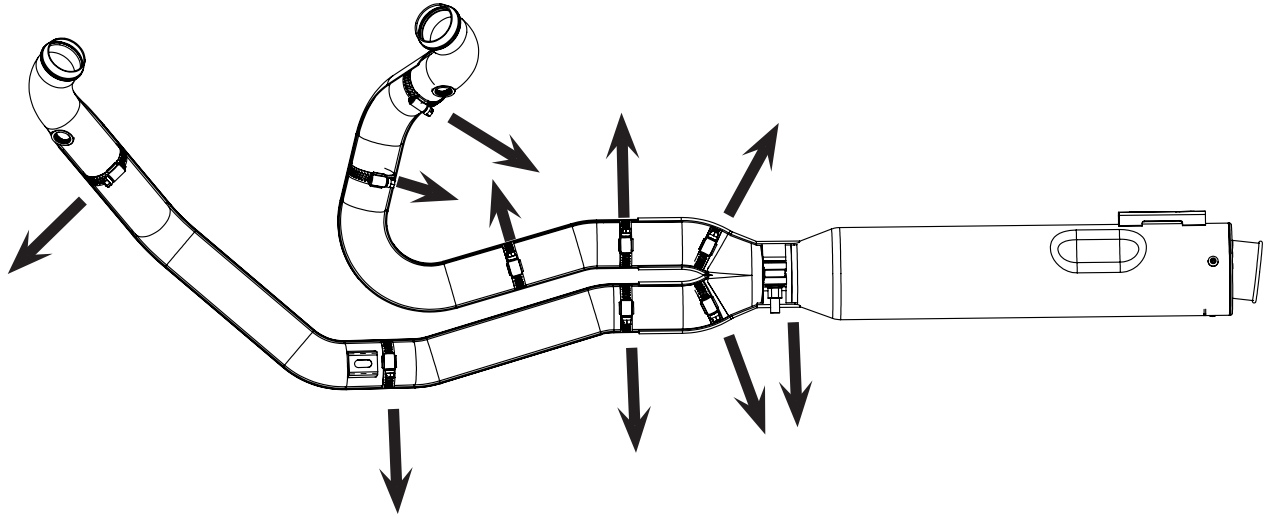

FIGURE 6

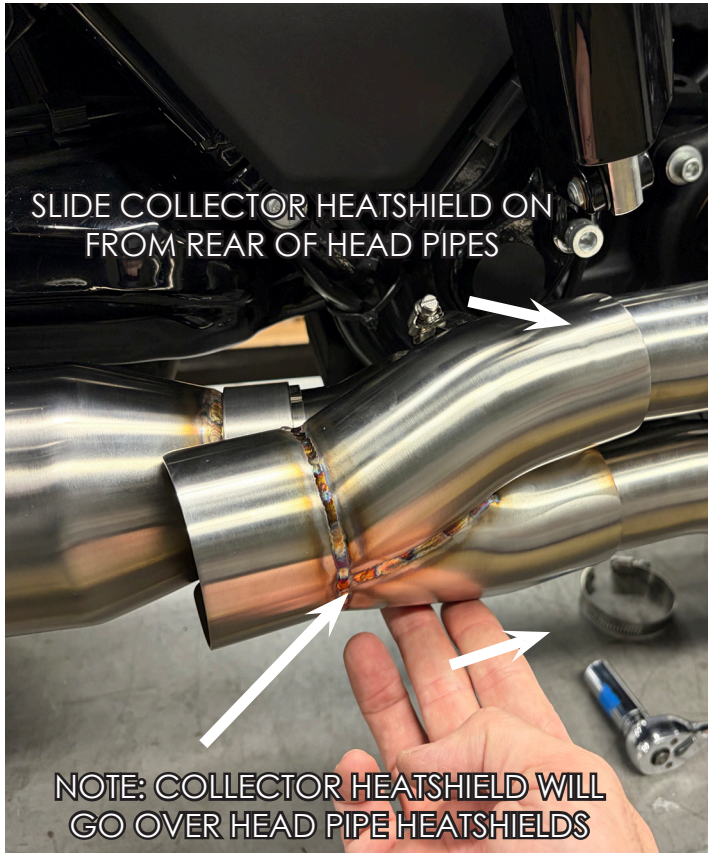

FIGURE 7



FIGURE 8



EXHAUST CARE (STAINLESS AND CHROME)

1. When installing a new set of stainless pipes, make sure your hands are clean and free of oil. After installation, thoroughly clean pipes with a soft cloth and cleaning solvent that will leave no residue (glass cleaner, alcohol, acetone, etc...) before starting the motorcycle.
2. It is considered normal for stainless steel exhaust systems to discolor due to heat.
3. High performance engine tuning utilizing a dyno will likely result in severe discoloration.
4. Avoid long periods of idling as this can cause discoloration. Intake leaks can cause the engine to run lean and overheat and this could lead to discoloration.
5. Make sure there are no exhaust leaks at the junction of the exhaust pipes and cylinder head. We recommend replacing gaskets if they are worn.

EXHAUST CARE (BLACK)

1. When installing a new set of black pipes, make sure your hands are clean and free of oil. After installation, thoroughly clean pipes with warm soapy water and a soft cloth. Dry with a clean towel to remove any residue before starting the motorcycle. Do NOT use anything abrasive to clean pipes.
2. Avoid long periods of idling as this can cause discoloration.
3. Intake leaks can cause the engine to run lean and overheat, this could lead to discoloration.
4. Make sure there are no exhaust leaks at the junction of the exhaust pipes and cylinder head. We recommend replacing gaskets if they are worn.

Emissions Notice:

In California, in order to meet Air Resources Board emissions requirements, certain aftermarket part applications have been identified as replacements, and others have received ARB Executive Orders. All other emissions related aftermarket parts are for competition use only. A list of replacement parts and EO parts, and corresponding fitment is provided at vanceandhines.com/california.

Warranty:

All Vance & Hines products are warranted against defects in material and workmanship for a period of 90 days. This warranty does not cover discoloration or rust. This warranty shall be limited to the repair or replacement of the product, which may be proven defective under normal use. Vance & Hines will not warranty any system that has been abused, misused, improperly installed or modified.

Dealers or distributors are not authorized to make dispositions binding upon Vance & Hines. Vance & Hines will not be responsible for any labor charges incurred in removing or replacing any system under warranty. A return authorization number and a copy of the original purchase invoice must accompany all returns. Parts returned without a return authorization may be refused.

Please Note: Every effort is made for Vance & Hines Exhaust Systems to provide improved cornering clearance. However, due to design and space limitations on some motorcycle models, ground and cornering clearance may not be improved and in some cases may be reduced. Be sure to follow proper installation instructions.

Vance & Hines warrants each Catalytic Exhaust System is designed and manufactured to conform at the time of initial retail purchase with the applicable California Air Resources Board (ARB) regulations for After-market Critical Emission Control Parts on Highway Motorcycles and is free from defects in materials and workmanship which would cause a motorcycle to fail to conform to those regulations for the following warranty periods (as applicable):

(1) If the Catalytic Exhaust System is installed on a highway motorcycle within four years of the date that the highway motorcycle is first acquired by an ultimate purchaser, the warranty period shall be 5 years or 30,000 km (18,641 miles), whichever first occurs, from the date of initial retail sale, or (2) If the Catalytic Exhaust System is installed on a highway motorcycle more than four years of the date that the highway motorcycle is first acquired by an ultimate purchaser, the warranty period will be three years or 15,000 km (9,320 miles), whichever first occurs, from the date of initial retail sale.

COVERAGE. The above described warranty periods apply only to emissions-related defects, such as the integrity of the catalytic converter. This warranty does not apply to cosmetic defects and does not apply to any defects resulting from situations described below under "LIMITATIONS." Catalytic Exhaust System with warranted defects shall be repaired or replaced by Vance & Hines, or by a dealer designated by Vance & Hines, at no cost to the owner. Vance & Hines will also be liable for damages to other motorcycle components proximately caused by a failure under warranty of the Catalytic Exhaust System.

OWNER'S OBLIGATIONS. The following obligations must be fulfilled by the Catalytic Exhaust System owner to maintain the validity of the emission defects warranty:

a. Owner is responsible for the performance of all emissions-related maintenance prescribed by the vehicle manufacturer. Vance & Hines recommends that you retain all receipts covering maintenance on your motorcycle related to any alleged defect, but Vance & Hines cannot deny warranty solely for the lack of receipts or for your failure to ensure the performance of all scheduled maintenance.

b. Owner is responsible notifying Vance & Hines as soon as a problem exists. Owner may be required to have the motorcycle inspected by a dealer designated by Vance & Hines at the dealer's place of business during customary business hours. Catalytic Exhaust System with warranted defects will be repaired or replaced in a reasonable amount of time, not to exceed 30 days.

c. Owner must present a copy of the proof of initial retail purchase date of both the Catalytic Exhaust System and motorcycle, issued at the time of purchase to Vance & Hines at the time warranty repairs or replacements are performed.

LIMITATIONS. This emission defects warranty shall not cover repair or replacement of the Catalytic Exhaust System required as a result of accident, misuse or neglect, repairs improperly performed, use of replacement parts or accessories not conforming to the motorcycle manufacturer's specifications which adversely affect performance and/or durability, alterations or modifications not recommended by the motorcycle manufacturer or Vance & Hines, and/or any motorcycle on which odometer mileage has been changed so that the actual mileage cannot be determined.

LIMITED LIABILITY. The liability of Vance & Hines under this emission defects warranty is limited solely to the remedying of defects in materials or workmanship of the Catalytic Exhaust System by Vance & Hines or a third party approved by Vance & Hines at that party's place of business during customary business hours. This warranty does not cover inconvenience or loss of use of the motorcycle, or transportation the Catalytic Exhaust System or the motorcycle on which the system is installed to Vance & Hines or a third party approved by Vance & Hines.

If you have any questions regarding your warranty rights and responsibilities, you should contact Vance & Hines at info@vanceandhines.com or (562) 921-7461.

NOTICE TO INSTALLER

The California Evaluation Procedures for Aftermarket Critical Emission Control Parts on Highway Motorcycles require that installers of aftermarket critical emissions control parts, such as the Vance & Hines Catalytic Exhaust System, warrant that such parts are installed correctly in accordance with the instructions set forth in this document, and that the installation will not cause the failure of the part to conform to the applicable requirements of the procedures or cause damage to any original part on the highway motorcycle due to incorrect installation. The installation warranty shall be 2

years or 12,000 kilometers (7,456 miles) from the date of the installation of the aftermarket critical emissions control part, whichever occurs first.

Installers and retailers of aftermarket critical emissions control parts, such as Vance & Hines Catalytic Exhaust System, keep documentation regarding the sale and/or installation of such parts, including part number/model, date of sale and/or installation, purchaser name and address, vehicle make, model and vehicle identification number. All such documentation must be maintained for a period of 5 years from the date of sale or installation and be made available upon request by California Air Resources Board staff.

INSTALLER WARRANTY

Installer warrants that this Vance & Hines Catalytic Exhaust System has been installed correctly, in accordance with the manufacturer's specified instructions, and that the installation will not cause failure of the Supersport 2-1 Catalytic Exhaust System to conform to the applicable requirements of the California Evaluation Procedures for Aftermarket Critical Emission Control Parts on Highway Motorcycles or cause damage to any original part on the highway motorcycle due to incorrect installation. This installation warranty shall be for two years or 12,000 kilometers (7,456 miles) from the date of the installation of the Catalytic Exhaust System, whichever occurs first.

COVERAGE. The above described installer's warranty periods apply only to installation-related defects, and not to the function or integrity of the catalytic converter, which is warranted by Vance & Hines. This installer's warranty does not apply to cosmetic defects and does not apply to any defects resulting from situations described below under "LIMITATIONS." Catalytic Exhaust System with warranted defects shall be repaired or replaced by Vance & Hines, or by a dealer designated by Vance & Hines, at no cost to the owner. Vance & Hines will also be liable for damages to other motorcycle components proximately caused by a failure under warranty of the Catalytic Exhaust System.

LIMITATIONS. Installer's warranty shall not cover repair or replacement of the Catalytic Exhaust System required as a result of accident, misuse or neglect, repairs improperly performed by someone other than installer, use of replacement parts or accessories not conforming to the motorcycle manufacturer's specifications which adversely affect performance and/or durability, alterations or modifications not recommended by the motorcycle manufacturer or Vance & Hines, and/or any motorcycle on which odometer mileage has been changed so that the actual mileage cannot be determined.

13861 ROSECRANS AVENUE / SANTA FE SPRINGS, CA 90670

SALES: (562) 921-5388

TECHNICAL: (562) 926-5291

FAX: (562) 802-0110

vanceandhines
.com