



# INSTALLATION INSTRUCTIONS

## WINCH MOUNT KIT

Part Number: 101510

Application: 2018 YAMAHA YXZ

### GENERAL SAFETY PRECAUTIONS

Your safety, and the safety of others, is very important. To help you make informed decisions about safety, we have provided installation and operating instructions and other information on labels and in this guide. This information alerts you to potential hazards that could hurt you or others. It is not possible to warn you about all potential hazards associated with this product, you must use your own good judgment.

**CARELESS INSTALLATION AND OPERATION CAN RESULT IN SERIOUS INJURY OR EQUIPMENT DAMAGE. READ AND UNDERSTAND ALL SAFETY PRECAUTIONS AND OPERATING INSTRUCTIONS BEFORE INSTALLING AND OPERATING THIS PRODUCT.**

This guide identifies potential hazards and has important safety messages that help you and others avoid personal injury or death. **WARNING** and **CAUTION** are signal words that identify the level of hazard. These signal words mean:

**▲WARNING** signals a hazard that could cause serious injury or death, if you do not follow recommendations. **▲CAUTION** signals a hazard that may cause minor to moderate injury, if you do not follow recommendations.

This guide uses **NOTICE** to call attention to important mechanical information, and **Note:** to emphasize general information worthy of special attention.

### **▲ WARNING**

#### **IMPACT AND MOVING PARTS ENTANGLEMENT HAZARD**

**Failure to observe these instructions could lead to severe injury or death**

- **Always** take time to fully read the Instructions and/or Operations Guide, and/or Basic Guide to Winching Techniques, in order to understand your winch and its operations.
- **Always** use extreme caution when drilling on any vehicle. Make sure that all fuel lines, brake lines, electrical wires, and other objects are not punctured or damaged when/if drilling on the vehicle. Thoroughly inspect the area to be drilled (on both sides of material) prior to drilling, and relocate any objects that may be damaged. Failure to inspect the area to be drilled may result in vehicle damage, electrical shock, fire or personal injury.
- **Always** wear safety glasses when installing this kit. A drilling operation will cause flying metal chips. Flying chips can cause eye injury.
- **Always** use extreme caution when cutting and trimming during fitting.
- **Always** remove jewelry and wear eye protection.
- **Never** lean over battery while making connections.
- **Never** route electrical cables:
  - o Across any sharp edges.
  - o Through or near moving parts.
  - o Near parts that become hot.
- **Always** insulate and protect all exposed wiring and electrical terminals.
- **Always** install terminal boots as directed in installation instructions.
- **Always** use appropriate and adequate care in lifting components into place.
- **Always** insure components will remain secure during installation and operation.
- **Always** tighten all nuts and bolts securely, per the installation instructions.
- **Always** perform regular inspections and maintenance on the plow mechanism, fasteners, cable and related hardware.
- **Always** replace all worn or damaged parts before operating.
- **Never** operate this WARN product with damaged or missing parts.

**Read installation and operating instructions thoroughly.**

WARN INDUSTRIES, INC. 12900 S.E. Capps Road,  
Clackamas, OR USA 97015-8903, 1-503-722-1200, FAX: 1-503-722-3000  
Customer Service: 1-800-543-9276  
Dealer Locator Service: 1-800-910-1122  
International Fax: 1-503-722-3005

## ⚠ CAUTION

### MOVING PARTS ENTANGLEMENT HAZARD

Failure to observe these instructions could lead to minor or moderate injury

- **Always** take time to fully read and understand the installation and Operations Guide included with this product.
- **Never** operate this product if you are under 16 years of age.
- **Never** operate this product when under the influence of drugs, alcohol or medications.

Read installation and operating instructions thoroughly.

## NOTICE

### EQUIPMENT DAMAGE

- **Never** tow vehicle by attaching a tow bar to the eyelets on the bumper.
- **Never** attach tow bars directly to the bumper. Damage to bumper may occur. WARN bumpers are not designed to be used for flat towing. Consult with the manufacturer of your tow bar system for the proper vehicle tow bar brackets.

Read installation and operating instructions thoroughly.

## TABLE OF CONTENTS

Tools Required.....	page 2
Torque Specifications.....	page 2
Parts List.....	page 3
Installation.....	page 4-6
Maintenance/Care.....	page 6

## TOOLS REQUIRED

- Standard sockets
- Metric sockets
- Socket extension
- Ratchet

## TORQUE SPECIFICATIONS

Please use the recommended torque specifications when assembling this product unless otherwise specified in the instructions.

FASTENER SIZE	FASTENER TORQUE		FASTENER SIZE	FASTENER TORQUE	
	lb-ft	(N.m)		lb-ft	(N.m)
1/4"	8	(11)	M4	(2)	3
5/16"	17	(23)	M5	(4.5)	6
3/8"	30	(40)	M6	(7.5)	10
7/16"	48	(66)	M8	(18)	25
1/2"	74	(100)	M10	(37)	50
9/16"	106	(144)			
5/8"	148	(200)			
3/4"	269	(364)			

# PARTS LIST

ID	Part No.	Description	Qty.	ID	Part No.	Description	Qty.
A1	102703	WINCH MOUNT BRACKET	1	B1	93078	M10 HEX HEAD BOLT	2
A2	102699	LOWER SKID PLATE BRACKET	1	B2	87232	LOCKING FLANGE NUT	2
				B3	65970	M8 X 1.25 X 25 FLANGE BOLT	4

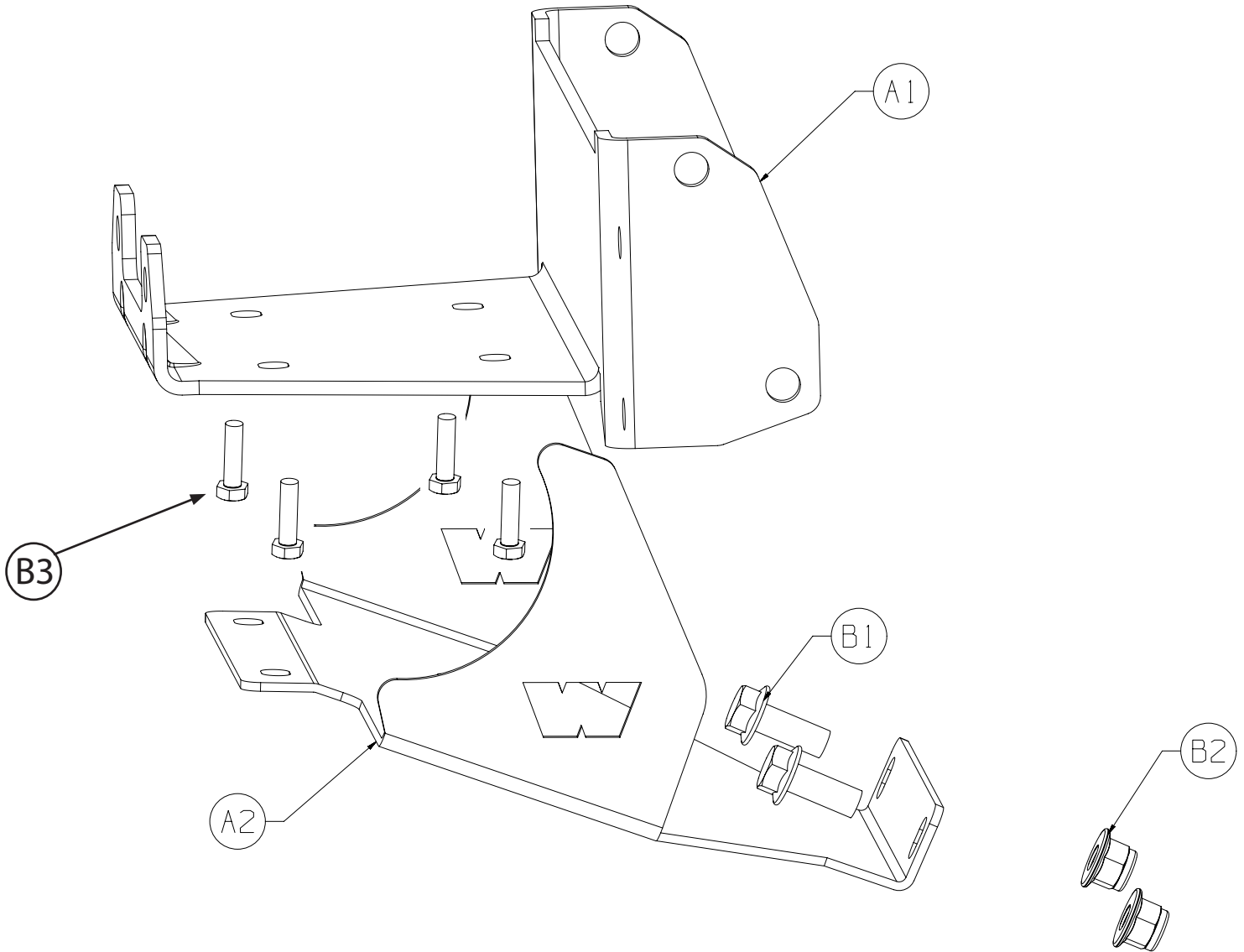

# INSTALLATION INSTRUCTIONS



Figure 1

1. Remove the bumper by removing the four factory bumper mounting bolts (two per side). **NOTE: Retain hardware. You will reuse bolts for the winch mount installation.**



Figure 2

2. Remove the two front factory skid plate bolts. **NOTE: Retain hardware.**

The skid plate will now hang down allowing room for the winch mount and lower skid plate bracket install.



Figure 3

3. Install winch mount (A1) using the factory bumper hardware previously removed in step 1.

Do not completely tighten hardware at this time.

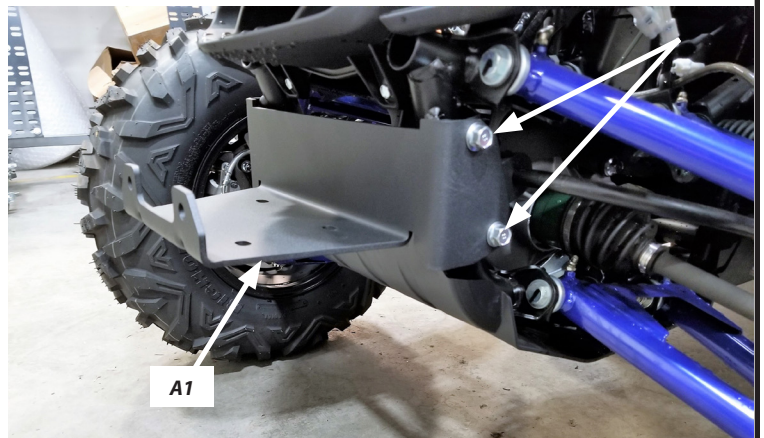

Figure 4



## INSTALLATION INSTRUCTIONS

4. Install the lower skid plate bracket (A2) using the supplied 10mm bolts (B1) and locking nuts (B2) hardware. Do not tighten completely at this time.

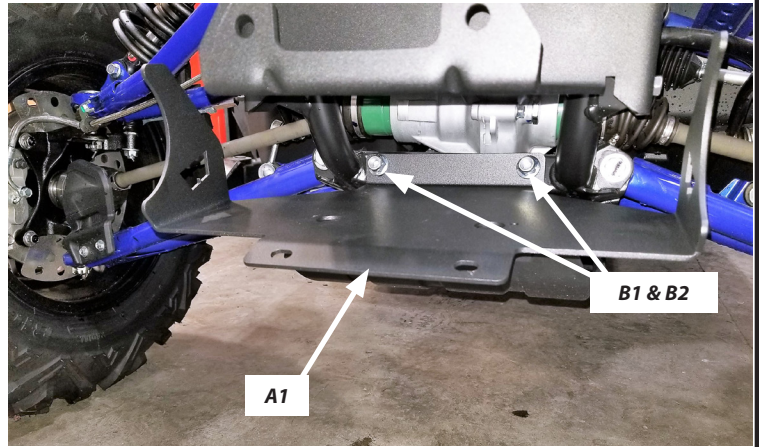

Figure 5

5. Place winch on mounting plate.
6. Secure winch in place by installing the two rear winch bolts (B3). Do not completely tighten at this time.

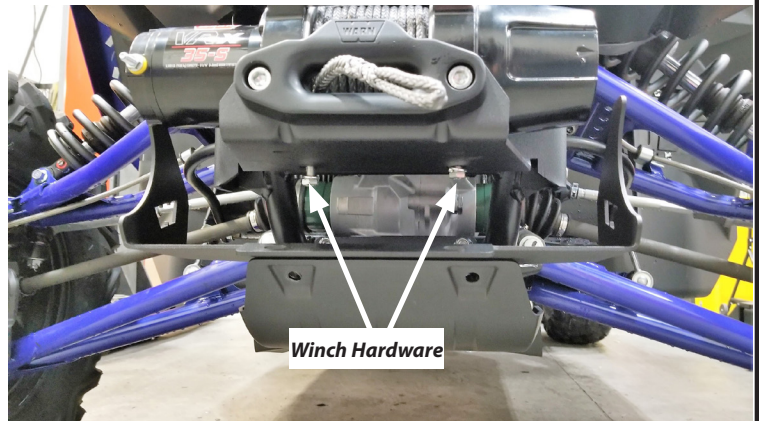

Figure 6

7. Lift lower skid plate bracket up to meet the winch mount.
8. Insert the front winch bolts (B3) through lower skid plate bracket, winch mount and into winch.
9. Tighten **ALL** hardware. **TIP: There are bolt access holes through the lower skid plate bracket to reach rear winch mount bolts.**

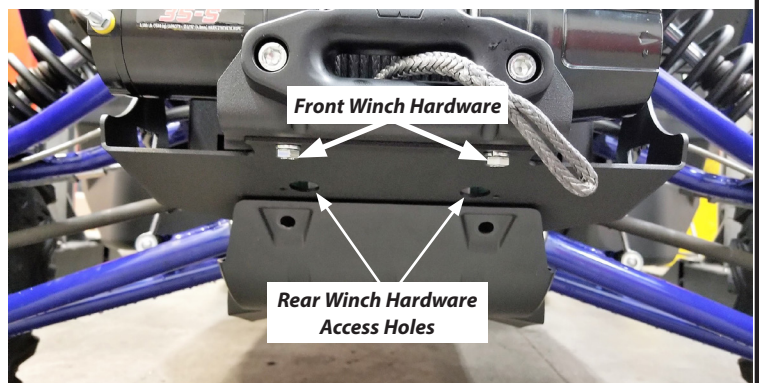

Figure 7

10. Lift the plastic skid plate up to meet the bottom of the lower skid plate bracket.
11. Attach the plastic skid plate using the factory hardware.
12. Tighten ALL hardware.



Figure 8

Your installation is now complete.



*Figure 12*

## MAINTENANCE / CARE

1. Inspect all parts on the winch, winch mount, and related hardware prior to each use. Replace all hardware that appears rusted or deformed.
2. Inspect all nuts and bolts on the winch, winch mount and related hardware prior to each use. Tighten all nuts that appear to be loose. Stripped, fractured, or bent bolts or nuts need to be replaced.
3. Check all cables prior to use. Replace cables that look worn or frayed.
4. Check all moving or rotating parts. Remove debris that may inhibit the part from moving freely.