

INSTALLATION INSTRUCTIONS

Accessory	Application	Publication No.
TOP CASE P/N 08L72-MKS-A00	CRF1100A/A4/D/D4	MII 17351
		Issue Date
		February 2020

Honda Dealer: Please give a copy of these instructions to your customer.

PARTS LIST

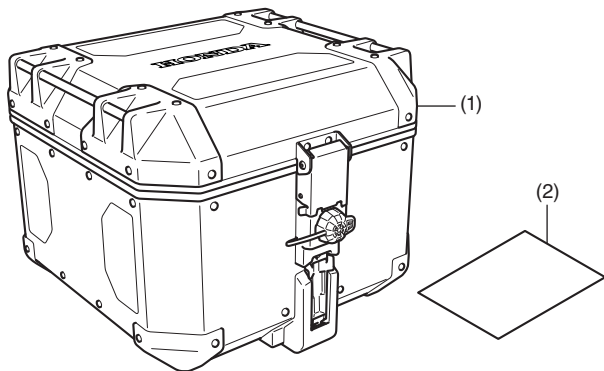

No.	Description	Qty
(1)	Top case	1
(2)	Installation Instruction URL	1

1 KEY INNER CYLINDER

(Wave key type)

- Do not use the [] slots.

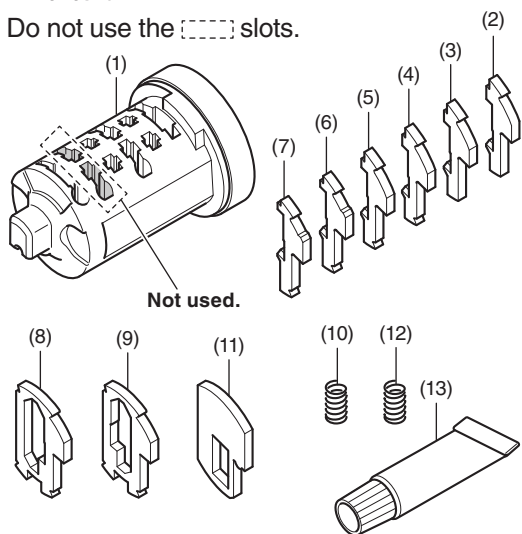

No.	Description	Qty
(1)	Inner cylinder	1
(2)	No.1 tumbler	6
(3)	No.2 tumbler	6
(4)	No.3 tumbler	6
(5)	No.4 tumbler	6
(6)	No.5 tumbler	6
(7)	No.6 tumbler	6
(8)	Sub-lock tumbler A	1
(9)	Sub-lock tumbler B	1
(10)	Spring (Silver)	13
(11)	Stopper tumbler	2
(12)	Stopper spring (Black)	2
(13)	Grease	1

REAR CARRIER

Sold separately

<CRF1100A/D only>

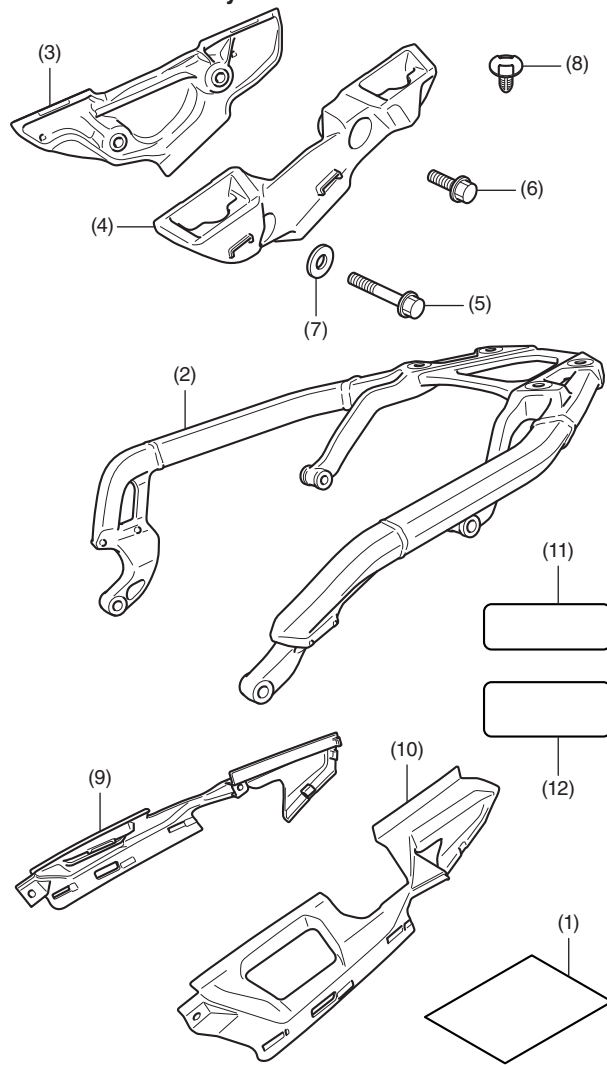

For installation, refer to the Installation Instructions of accessory.

No.	Description	Qty
(1)	Installation Instruction URL	1
(2)	Rear carrier	1
(3)	Right pannier bracket	1
(4)	Left pannier bracket	1
(5)	8 mm flange bolt	4
(6)	8 mm bolt	2
(7)	Washer	4
(8)	Clip	4
(9)	Right pannier bracket cover	1
(10)	Left pannier bracket cover	1
(11)	Label (MKK-D00)	1
(12)	Label (MFG-900)	1

TOP CASE MOUNT
Sold separately

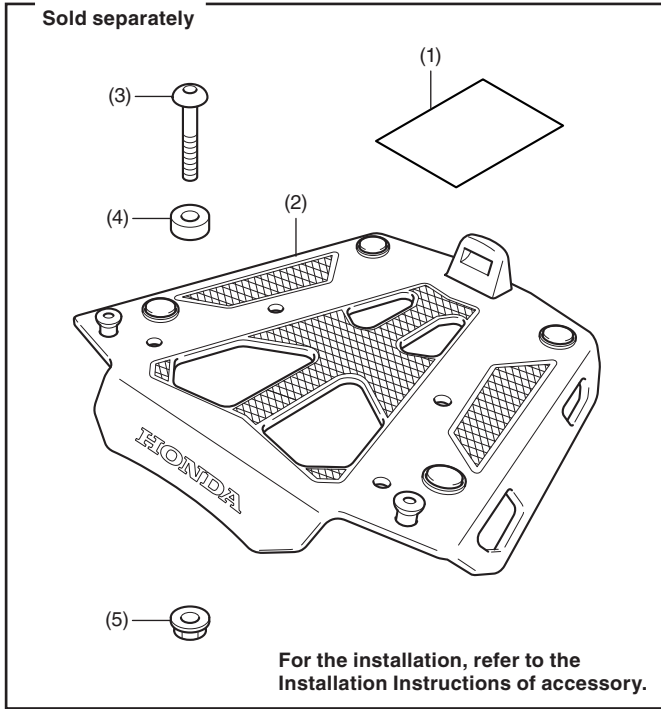

No.	Description	Qty
(1)	Installation Instruction URL	1
(2)	Carrier base	1
(3)	8 mm socket bolt	4
(4)	Collar	4
(5)	8 mm flange nut	4

MAXIMUM LOADING CAPACITY

- The weight of the cargo must not exceed the following maximum loading capacity:

Maximum Loading Capacity	
Top Case	13.2 lb (6.0 kg)

< Notes regarding the key cylinder >

- This product is used to assemble a key cylinder matching the motorcycle key by combining six types of tumblers.
- When this key cylinder is installed in a box or similar equipment, the installed equipment can be operated with the motorcycle key.

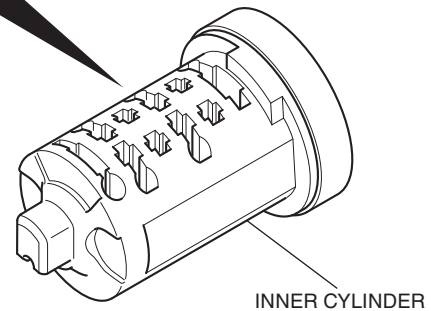
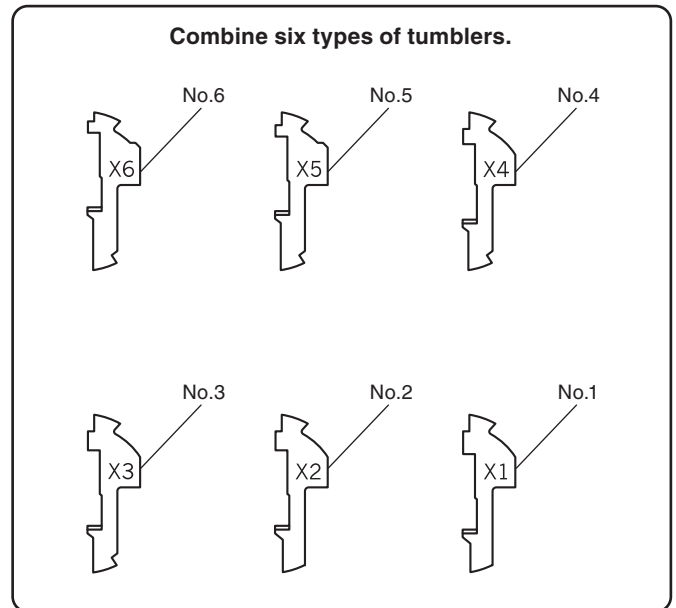

INSTALLATION

1. The two sub-lock tumbler types shown are provided.
 - The  part has a different slot for each of the two sub-lock tumbler types.
 - As the tumblers are small, keep them in the bag until they are used.

SUB-LOCK TUMBLER A

SUB-LOCK TUMBLER B

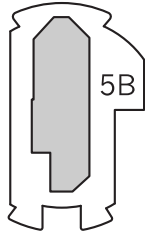
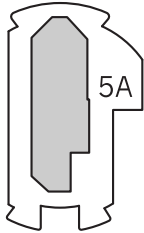

The stopper tumbler will be used later.

STOPPER TUMBLER



2. The six tumbler types shown are provided.
 - The  part has a different width for each of the six tumbler types.
 - As the tumblers are small, keep them in the bag until they are used.

No.6

No.5

No.4

No.3

No.2

No.1

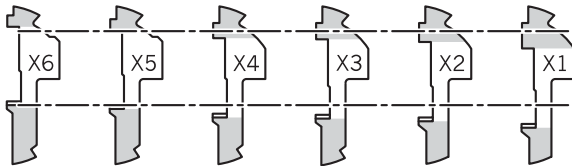

3. Install the tumblers and springs (silver) as shown.
- **First install four No.1 tumblers.**
 - **Note the installed tumbler in the chart below.**

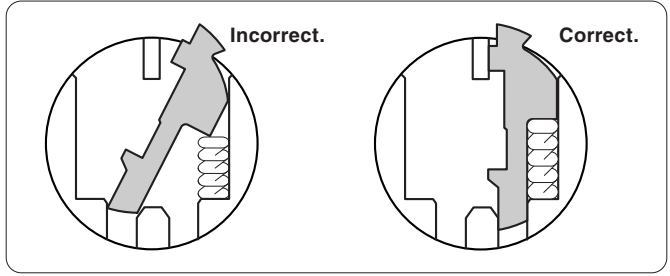
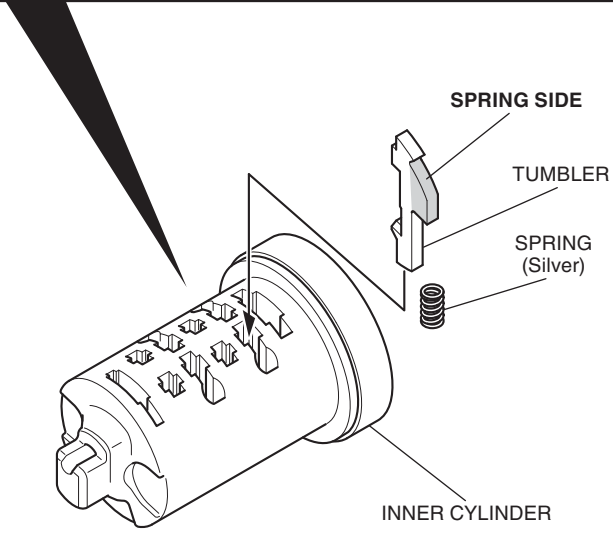
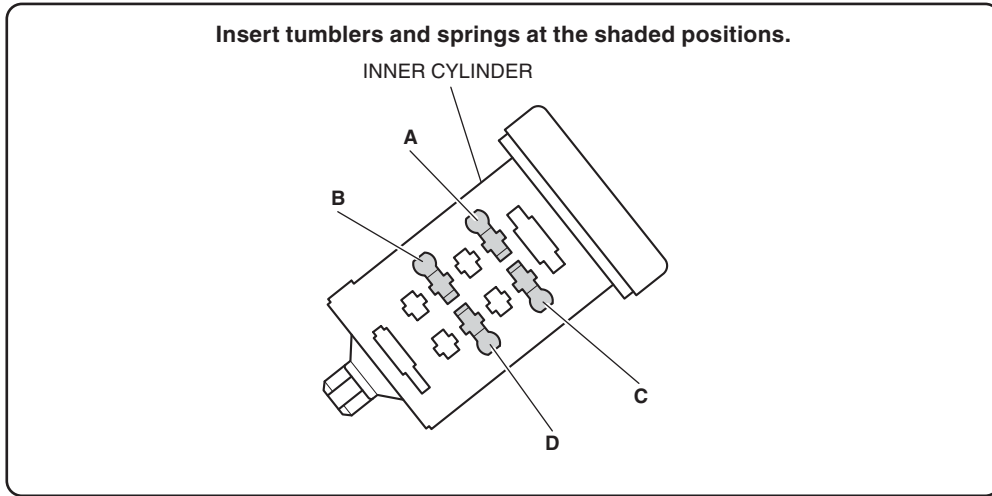

	Position A	Position B	Position C	Position D
No.1 tumbler				
No.2 tumbler				
No.3 tumbler				
No.4 tumbler				
No.5 tumbler				
No.6 tumbler				

4. Insert the key as shown.
- **Lightly press down on the tumblers from above, then insert the key.**

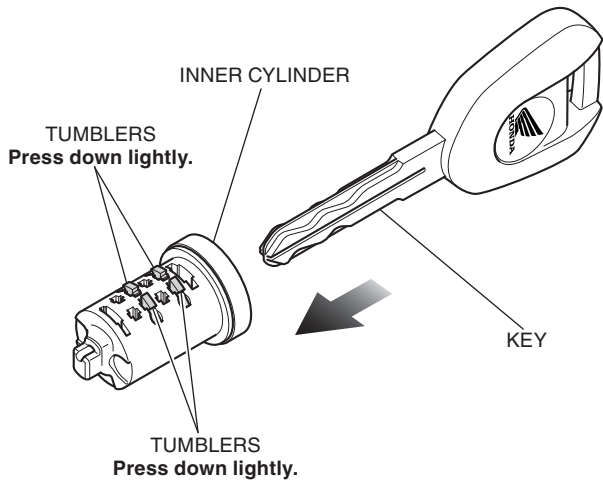

5. Confirm that some tumblers are projecting. Mark the positions of the projected tumblers.
- **The positions where tumblers project and the projecting height differ according to the key.**

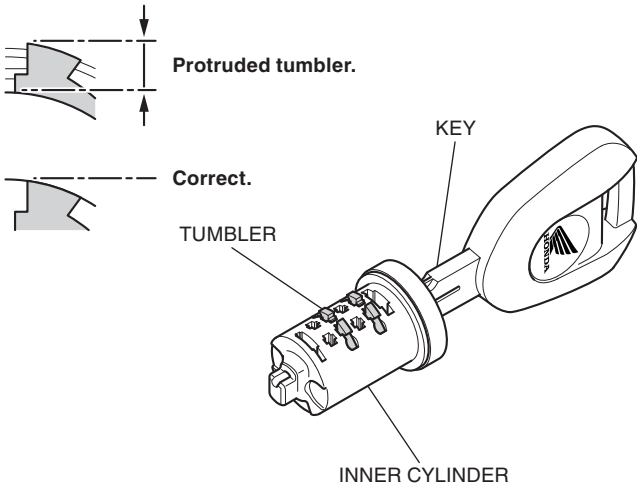

6. Press down lightly on the tumbler, pull the key out.
- **The tumbler spring may jump out when the tumbler is not pressed down lightly.**

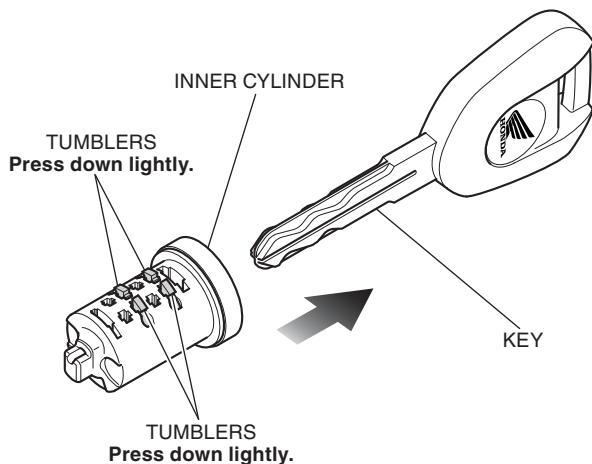

7. Pull out the projecting tumbler(s).
- **Leave the spring(s) installed.**

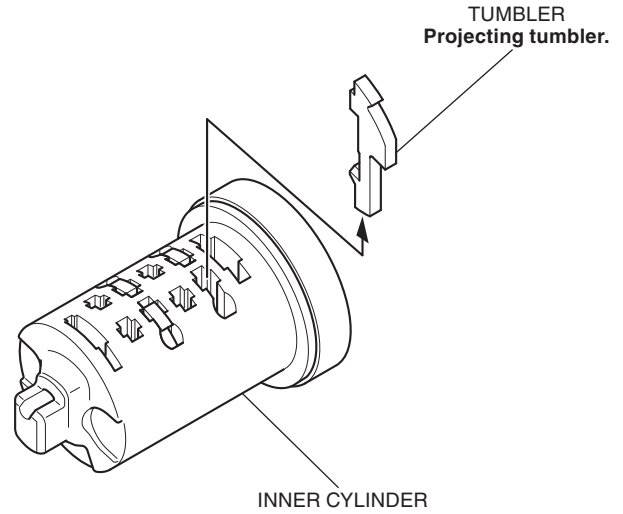

8. Insert a different tumbler(s) at the marked positions.
- **Start with the No. 2 tumblers and continue sequentially.**

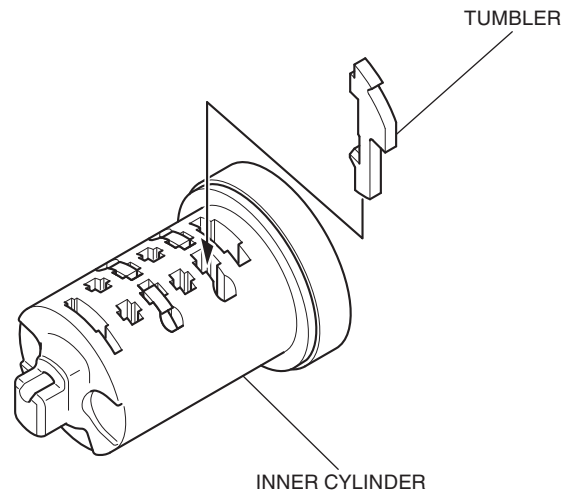

9. Repeat steps 4 to 8, inserting different tumblers at the marked positions until no tumblers are projected.
- **Lightly press down on the tumblers from above, then insert the key.**

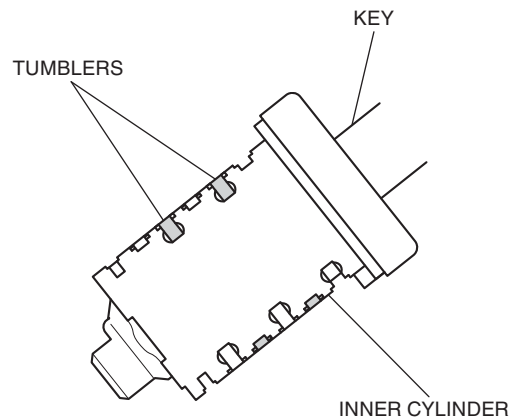

10. Install the tumblers and springs (silver) to the opposite side of the inner cylinder as shown.

- **First install two No.1 tumblers.**

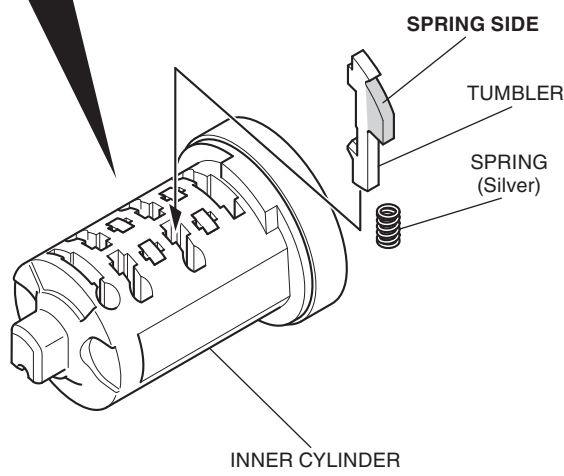
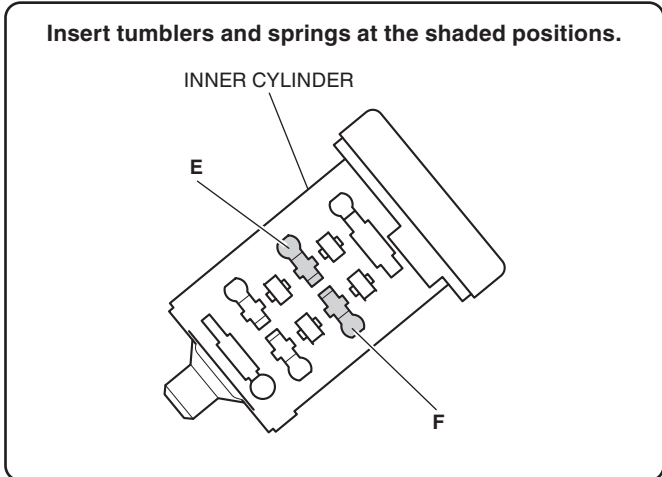

- **Note the installed tumbler to the chart below.**

	Position E	Position F
No.1 tumbler		
No.2 tumbler		
No.3 tumbler		
No.4 tumbler		
No.5 tumbler		
No.6 tumbler		

11. Use steps 4 through 8 to assemble the reverse side inner cylinder in the same manner.

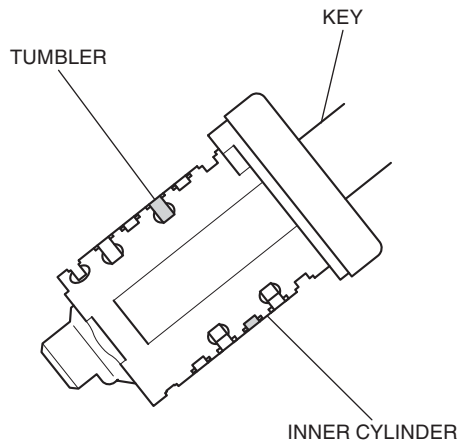

12. Install the sub-lock tumbler as shown.

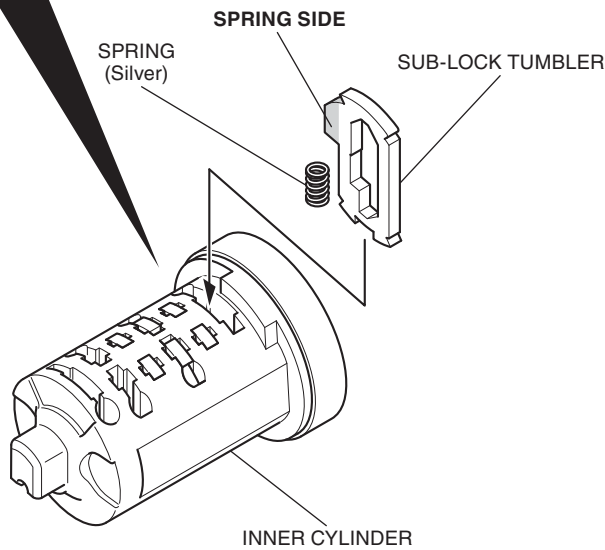
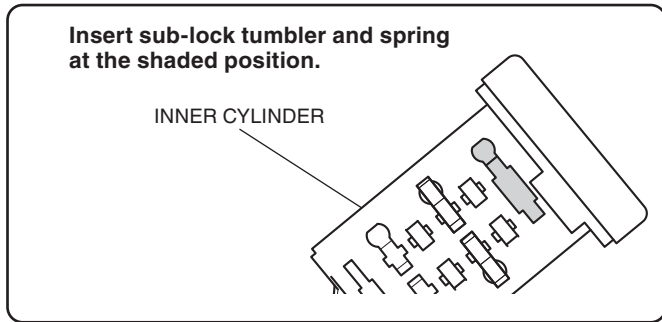

- **Note the installed tumbler to the chart below.**

Sub-lock tumbler A	
Sub-lock tumbler B	

13. Confirm that sub-lock tumbler is not projecting.
- **If the tumbler is projected, change to another sub-lock tumbler and recheck.**

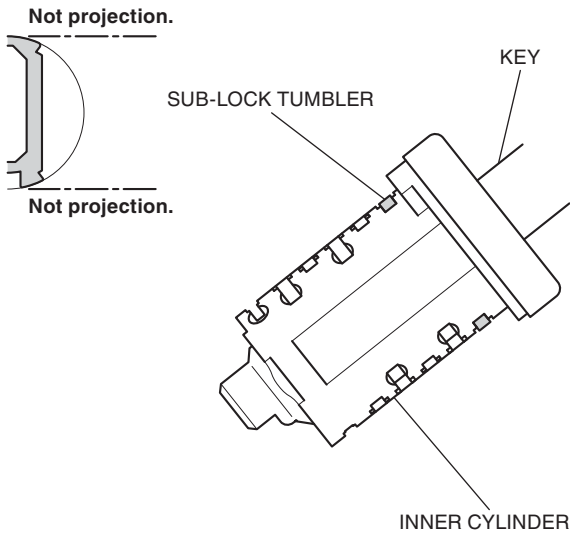

14. Remove the cap as shown.

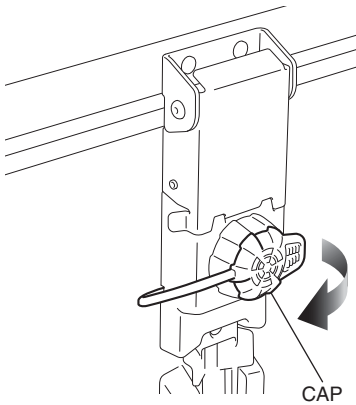

15. Insert the assembled inner cylinder into the cylinder body as shown.
- **Confirm the inner cylinder turns clockwise smoothly.**

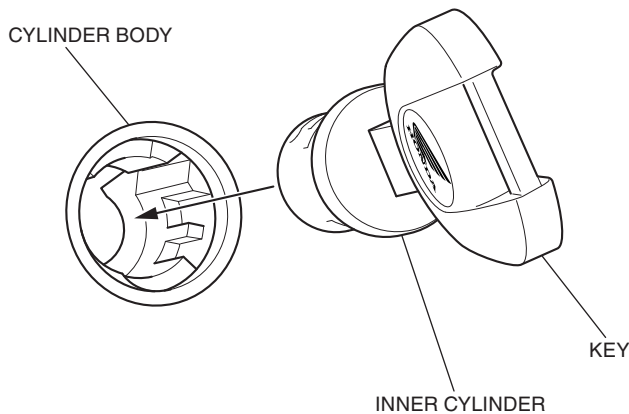

16. Pull out the inner cylinder.
17. Press down lightly on the tumblers and pull out the key.

18. Install the stopper tumbler and stopper spring (black) as shown.

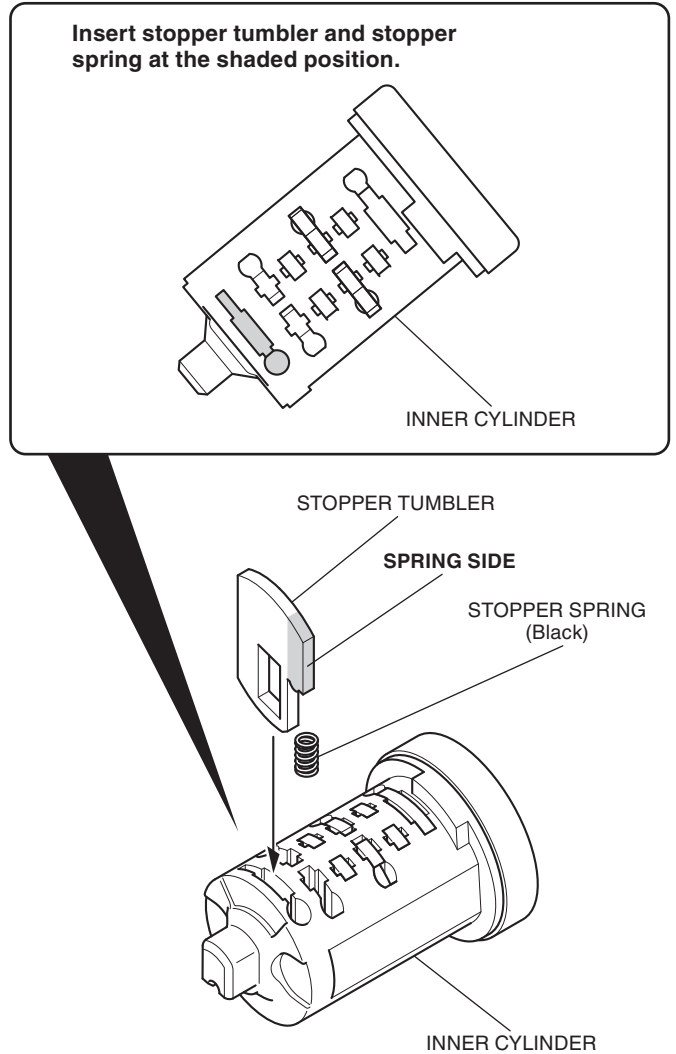

19. Insert the key as shown.
- **Lightly press down on the tumblers from above, then insert the key.**
 - **Confirm that the stopper tumbler jumps out.**

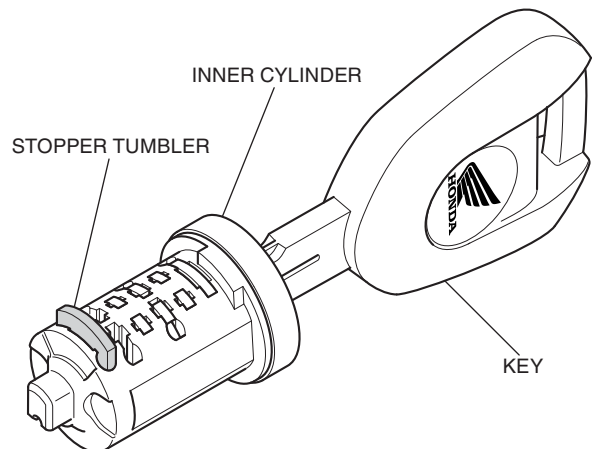

20. Apply grease to the shaded areas as shown.
- Apply to the tumbler and to the outer circumference of the inner cylinder.
 - Only use the supplied grease.

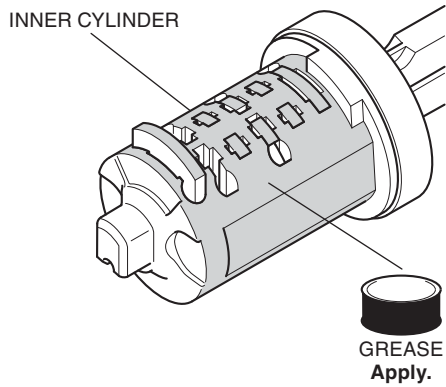

21. Install the inner cylinder by sliding the stopper tumbler along the slide guide while rotating it.
- If the inner cylinder cannot be inserted, confirm no tumblers other than the stopper tumbler, are projecting.

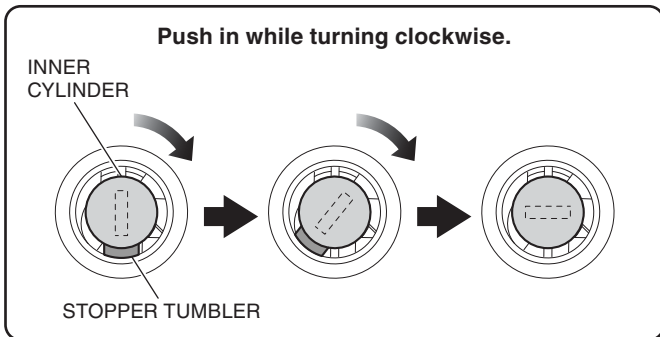
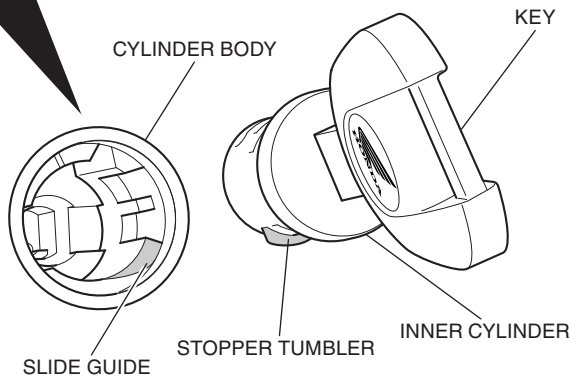
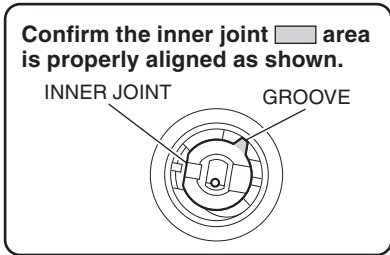

22. Pull out the key and check that the inner cylinder does not come out.

USING THE TOP CASE

How to Open the Top Case

1. Remove the cap as shown.

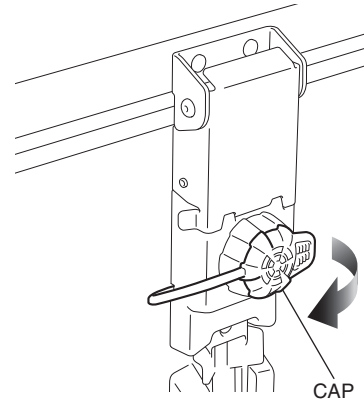

2. Insert the key and unlock by turning the key clockwise

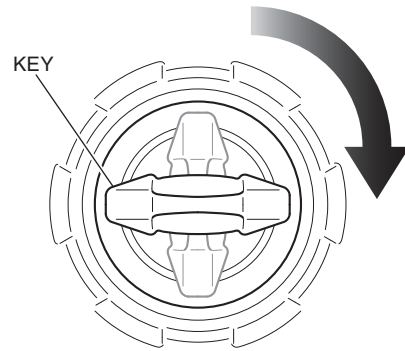

3. Pull the hinge up as shown.

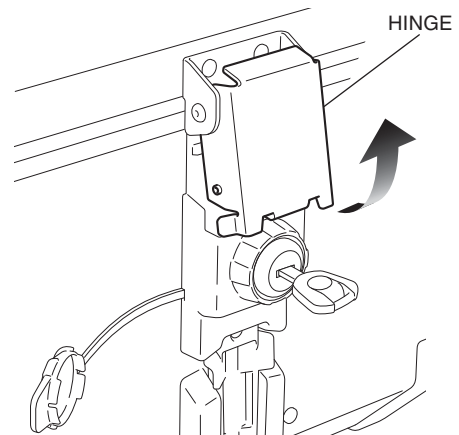

4. Release the hinge from hinge bar as shown.

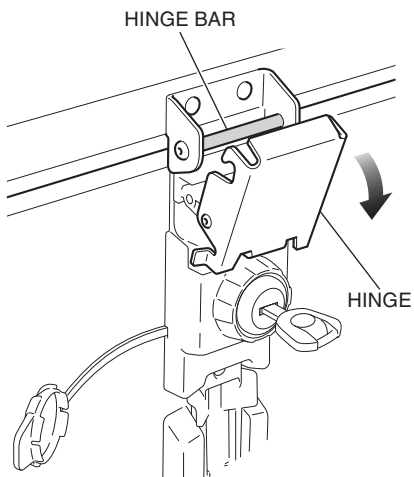

5. Open the lid as shown.

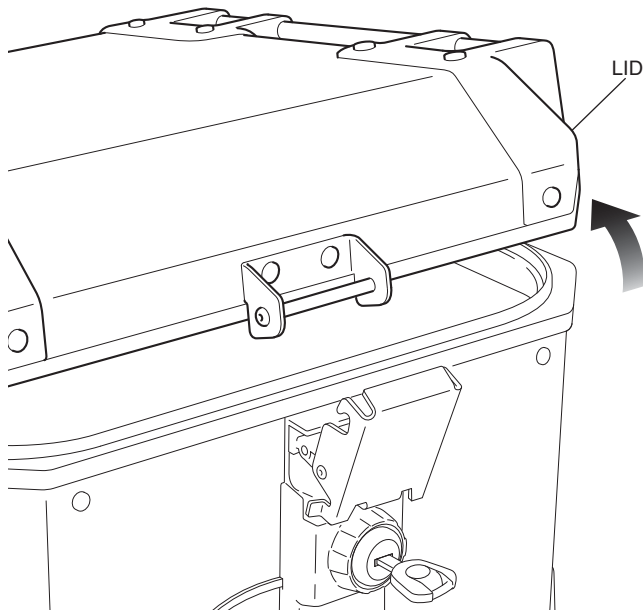

How to Close the Top Case

1. Close and lock the top case in the reverse order of opening.
 - **Be careful not to have any stored item pinched when the top case is closed.**

How to Install the Top Case

1. Install the rear carrier (sold separately).
 - **Perform this step on CRF1100A/D only.**
2. Install the top case mount (sold separately).
3. Insert the top case into the front bosses as shown.
 - **Installation can be done with the key in the lock or unlock position.**
 - **Installation can be done without inserting the key.**

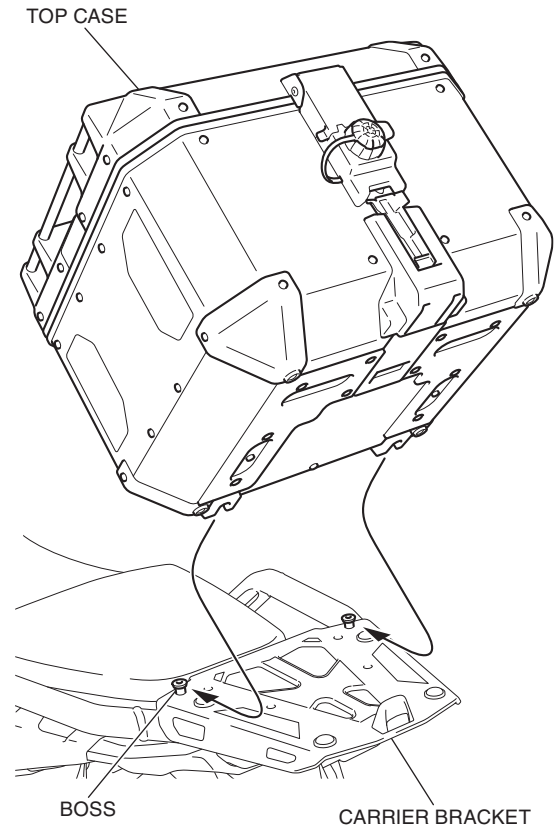

4. Install the top case by aligning the hole of top case with the hook.
 - **When the top case can not be installed, check the lever for proper installation.**

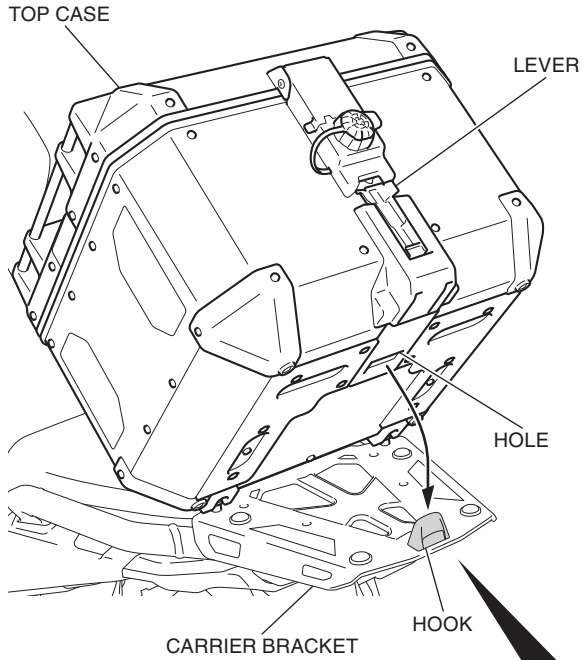

Lower the top case until the indicator (red) is hidden as shown.

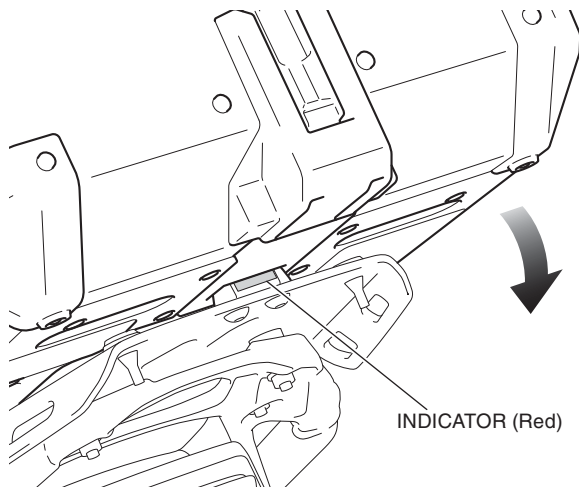

5. If the key is inserted, pull it out and install the cap.
6. Check that the top case is installed securely by shaking the top case taking care not to knock the motorcycle down.
 - **The top case can come off during riding unless it is installed securely.**

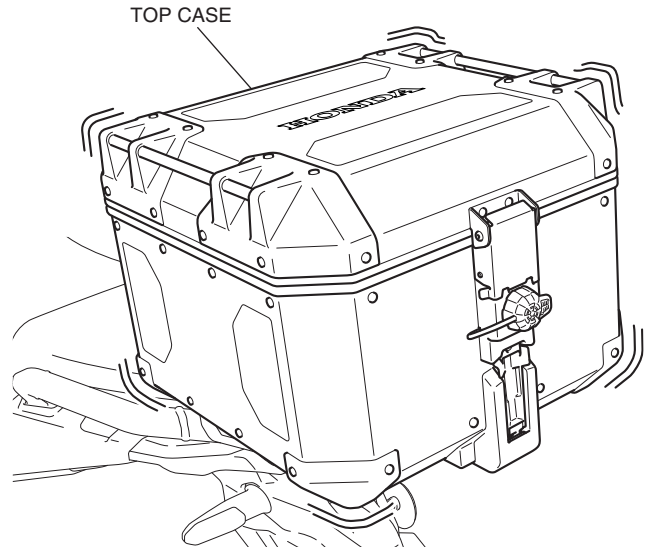

How to Remove the Top Case

1. Remove the cap as shown.

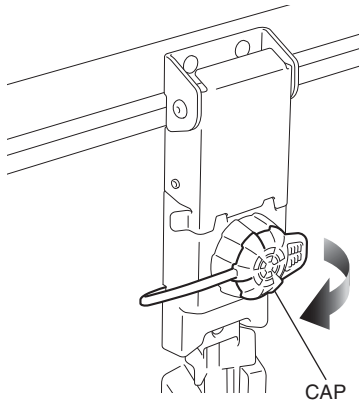

2. Insert the key and release the lock by turning the key clockwise

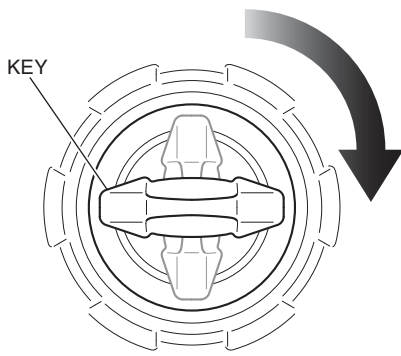

3. Pull the lever as shown.

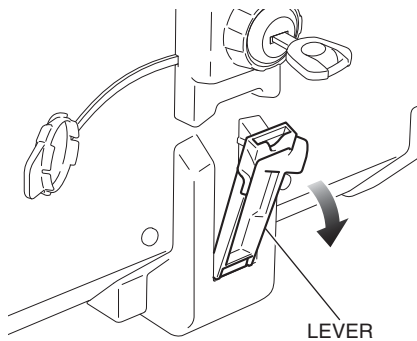

4. Remove the top case in the reverse order of installation.

How to Store the Top Case inner bag

1. Open the top case and store the top case inner bag.
2. Close the top case.
 - **Be careful not to have any stored item pinched when the top case is closed.**