

Congratulations, you have purchased the finest exhaust system available for your motorcycle. Your Vance & Hines exhaust is designed and crafted for performance, quality, and style. Please follow the instructions below, check exhaust system for missing or damaged parts and if you need any assistance please contact our technical support line (562) 921-7461.

FOR CLOSED COURSE COMPETITION USE ONLY. NOT INTENDED FOR STREET USE.

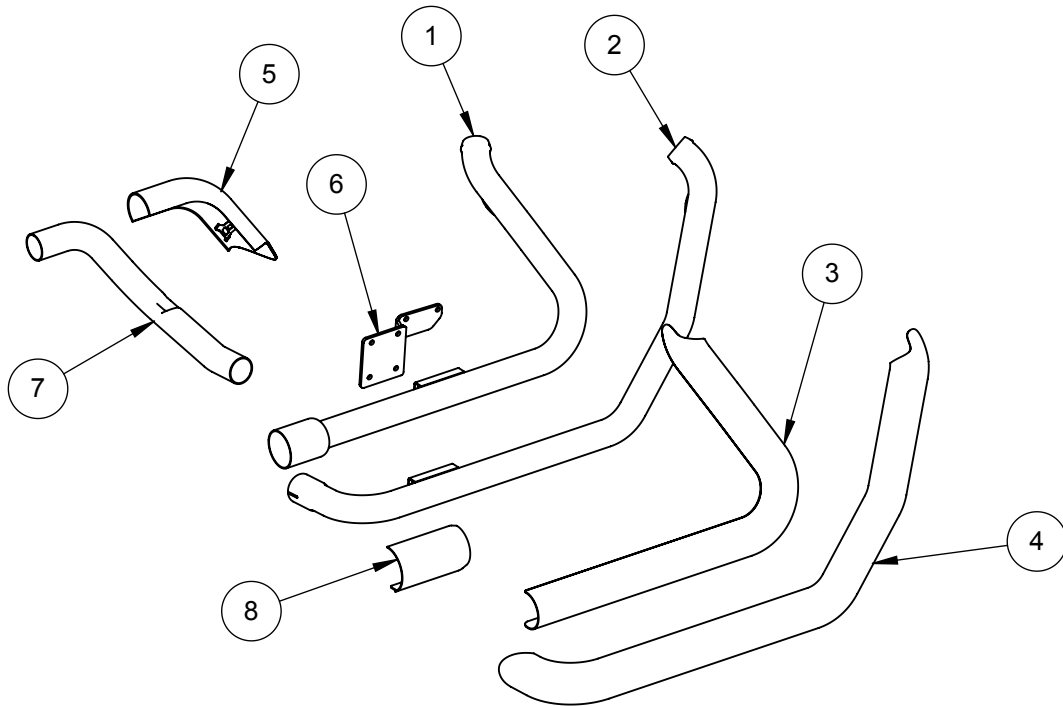

PARTS LIST

NO.	PART NO.	Description	Qty.
1	D273FC	Rear Head Pipe	1
2	D272FC	Front Head Pipe	1
3	D273HC	Rear Heat Shield	1
4	D272HC	Front Heat Shield	1
5	D557HC	Left Side Crossover Heat Shield	1
6	578-P	Bracket	1
7	D274FC	Crossover Head Pipe	1
8	D271HC	Transition Heat Shield	1
9	A288HW	Nylon Cable Tie	2
10	A335HW	Torca Band Clamp	1
11	A276HW	No. 36 Hose Clamp	1
12	A270HW	No. 20 Hose Clamp	9
13	A233CC	Tube Clamp	1
14	A195HW	Nut Plate	2
15	A644ST	18mm-12mm O2 Adpator	2
16	A240HW	5/16-18 x 5/8 FHS	4
17	A803HW	3/8-16 Carriage Bolt	1
18	A826HW	3/8-16 x 2.25 SHCS	1
19	A828HW	3/8-16 x 3.5 SHCS	1
20	1102-P	Crossover Bracket	2
21	A667HW	Floorboard Spacer	1
22	A902HW	Floorboard Spacer, Front	1
23	A265HW	3/8-16 Lock Nut	1
24	A286HW	3/8 Split Washer	2
25	A106HW	3/8 Flat Washer	1

HARDWARE

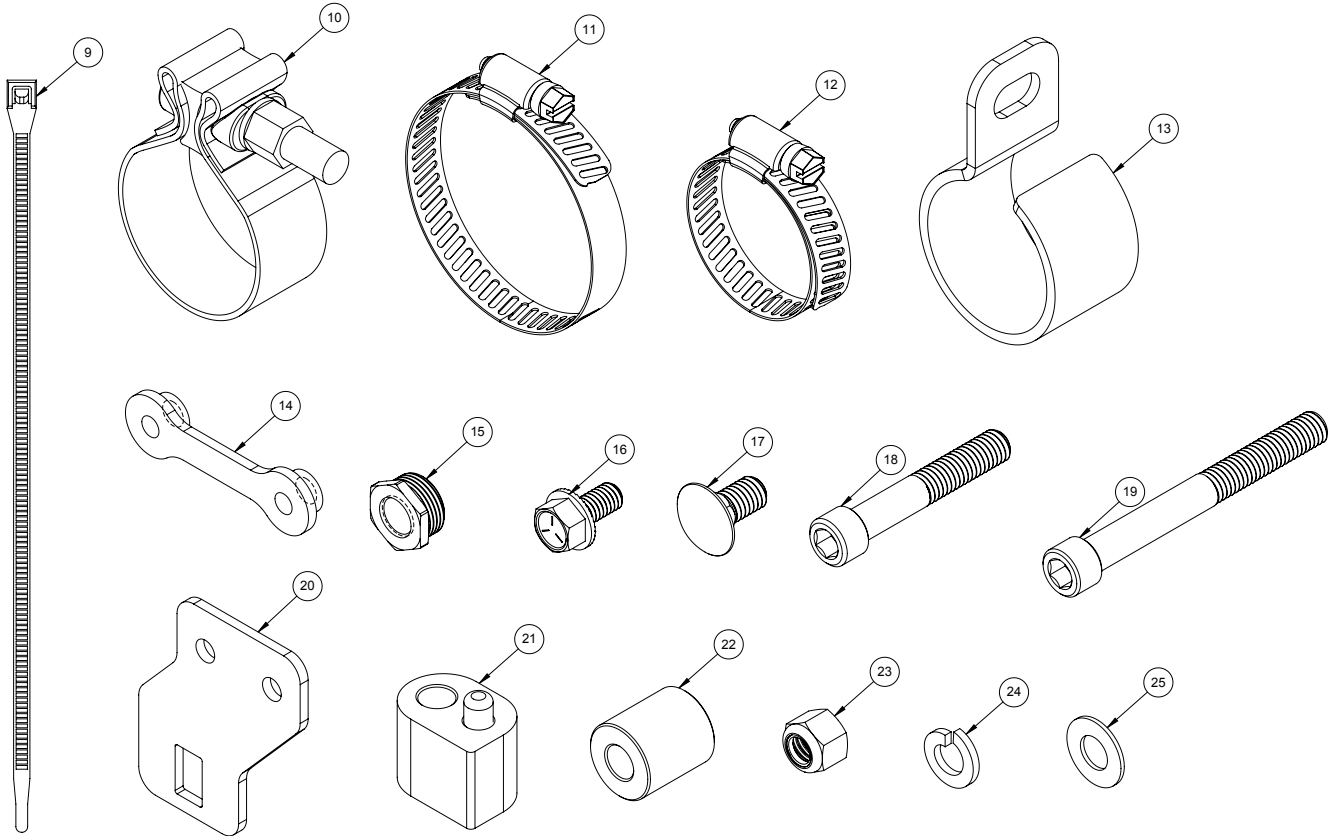

TOOLS REQUIRED

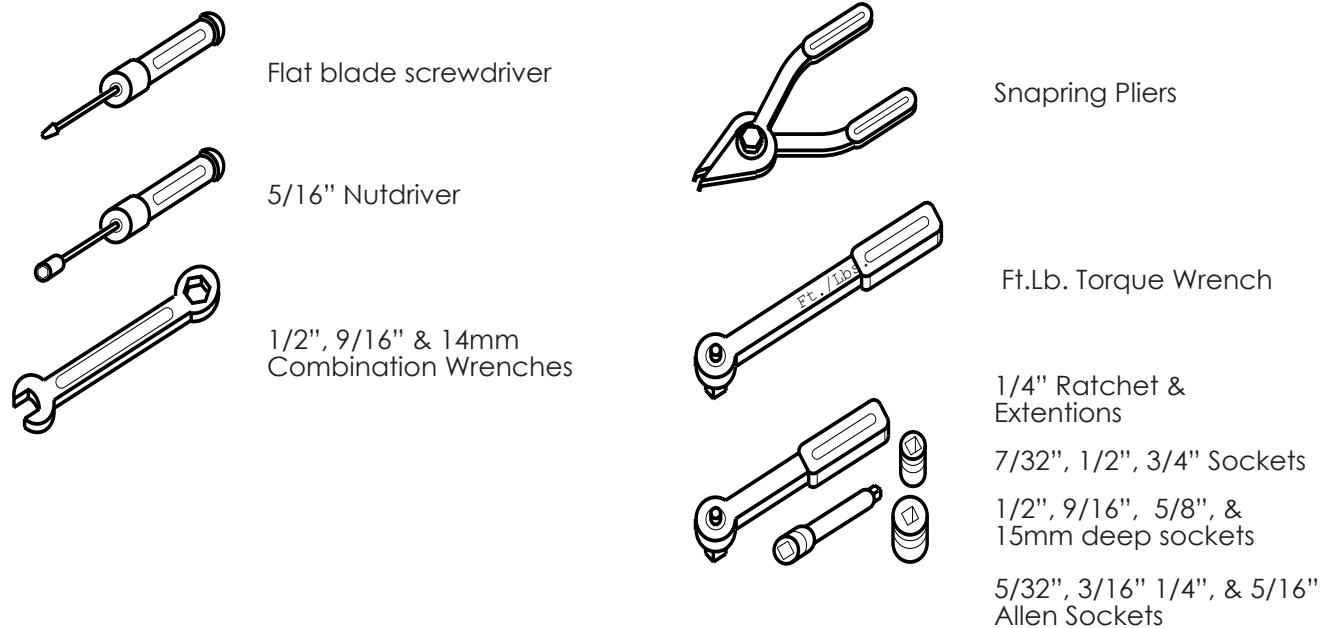

STOCK EXHAUST SYSTEM REMOVAL

1. Remove both left and right saddlebags and set them aside. Remove the right side panel.
2. Loosen the Torca band clamp on the front end of muffler(s). Save this for re-use.
3. Remove the two bolts and washers that mount the muffler(s) to the saddlebag supports. Save these for re-use.
4. Remove the muffler(s) and set aside. **NOTE:** It may be necessary to use a penetrating lubricant to loosen muffler(s) from the head pipe.
5. Locate and unplug the O2 sensor wires from the wiring harness (Grey and Black connectors located behind right side panel) and remove cable ties holding wires to frame. Feed the end of the wires through the frame so they are free from the motorcycle. **NOTE:** Pay attention to wire routing for re-installation.
6. Remove the right side floor board.
7. Remove the right side passenger floor board. (If equipped)
8. Loosen head pipe clamp connecting the left side muffler to the rear crossover header and the mount bracket on the backside of the oil pan. Remove the crossover section from the head pipe and the head pipe clamp.
9. Remove the mount clamp located behind the oil pan. Save hardware.
10. Remove nut from front headpipe mounting bracket and stud located to the right of the transmission cover. The hardware will not be reused.
11. Loosen the heat shield clamps on both front and rear exhaust pipes.
12. Remove the two flange mounting nuts from each head pipe, located at the cylinder head. Carefully remove the head pipes and set aside.
13. Remove stud that was mentioned in step 10.
14. Carefully remove the O2 sensors from the stock head pipes and save for re-use with the new system.
15. Carefully remove the exhaust port flanges and circlips from the stock exhaust system using snapping pliers. **NOTE:** If circlips look bent or twisted, replace them.

VANCE & HINES EXHAUST INSTALLATION

1. Check the exhaust gaskets for damage, and replace if necessary. Part# 65324-83B.
2. Remove transmission side cover. Remove two lower transmission housing bolts.
3. Install the head pipe mounting bracket to the transmission housing and torque to 13-16 ft-lbs. (**Figure 1**)
4. Remove header assembly and heat shields from protective packaging. Place each heat shield on a non-abrasive surface such as blanket or carpet. Using a felt tip pen, mark outside edge of each heat shield to show location of mounting clips that hose clamps will loop through (**Figure 4**).
5. Lay header assembly into heat shields and loosely install the #20 hose clamps (supplied) into mounting clips. Screw heads should be accessible when the system is installed on motorcycle for adjustment purposes (**Figure 4**).

VANCE & HINES EXHAUST INSTALLATION CONTINUED

6. Apply a small amount of anti-sieze compound to the threads of the oxygen sensors and install them into the new head pipe. Install supplied 18mm to 12mm oxygen sensor adapter then install the 12mm oxygen sensors (Grey connector into the front head pipe, Black connector into the rear head pipe.) Models using 18mm wideband oxygen sensors install the sensor directly into the head pipe.
7. Install flanges and circlips from stock system onto the new header pipes.
8. Using stock flange nuts, carefully install the header assembly onto the motorcycle. Finger tighten only at this time.
9. Install the nut plates and the 5/16 x 5/8 flange bolts (supplied) to attach the head pipes to the transmission bracket. Do not tighten at this time.
10. Install Torca Band Clamp (supplied), with the nut facing down, on the short side expanded end of the front head pipe (D272FC). Do Not tighten clamp at this time.
11. Align pipes on motorcycle so the gap between the two heat shields is parallel where they run together. Tighten the exhaust port flange nuts and the 5/16" x 5/8" flange head bolts on main bracket.
12. Attach crossover pipe clamp to bracket using carriage bolt, washer, and lock nut (supplied). Note: Carriage bolt should be placed through the square slot on the crossover mount bracket (**Figure 2**).
13. Loosely attach the heat shield (D557HC) to crossover header (D274FC) and slip it into the front head pipe.
14. Tighten the stock 1/4"-20 screws securing the bracket to the oil pan, then rotate crossover head pipe (D274FC) to proper position for muffler being used.
15. Install mufflers of your choice onto both head pipes and secure to saddlebag support.
16. Loosely install transition heatshield using supplied #36 hose clamp. Align and tighten heatshields.
17. Tighten the Torca band clamp securing the crosspipe to the head pipe.
18. Route O2 sensor wires away from hot areas of the motorcycle. Use the nylon cable ties (supplied) to secure the O2 sensor wires to the frame. Plug the O2 sensor wires back into the wiring harness, grey into grey, black into black. Re-install the right side panel.
19. Install 3/8" lock washers (supplied) on both 3/8"-16 (2.25" & 3.5" long) socket cap screws (supplied). Using these bolts re-install the floor board with two machined spacers (supplied) on the forward mount (A902HW) and back mount (A667HW). (Figure 3)
NOTE: Machined spacers are located between the floor board supports and floor board mount plate.
20. Re-install the right side passenger floorboard, right side panel, then saddlebags.
21. Be sure to tighten all hardware before starting your motorcycle.
22. After installation and before starting the motorcycle, completely clean pipes and mufflers with a cleaning solvent and a clean soft cloth that will not leave residue. **NOTE:** Any residue, oil, or fingerprints will stain the finish when the metal heats up.

EXHAUST CARE

- 1.** When installing a new set of chrome pipes, make sure your hands are clean and free of oil. After installation, thoroughly clean pipes with a soft cloth and cleaning solvent that will leave no residue before starting the motorcycle.
- 2.** Avoid long periods of idling as this can cause discoloration.
- 3.** Intake leaks can cause the engine to run lean and overheat, this could lead to discoloration.
- 4.** Make sure there are no exhaust leaks at the junction of the exhaust pipes and cylinder head. We recommend replacing gaskets if they are worn.

FIGURE 1

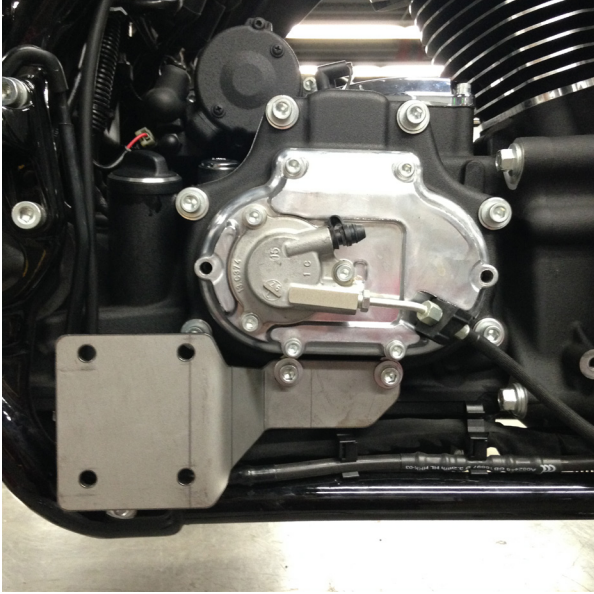

FIGURE 2



FIGURE 3

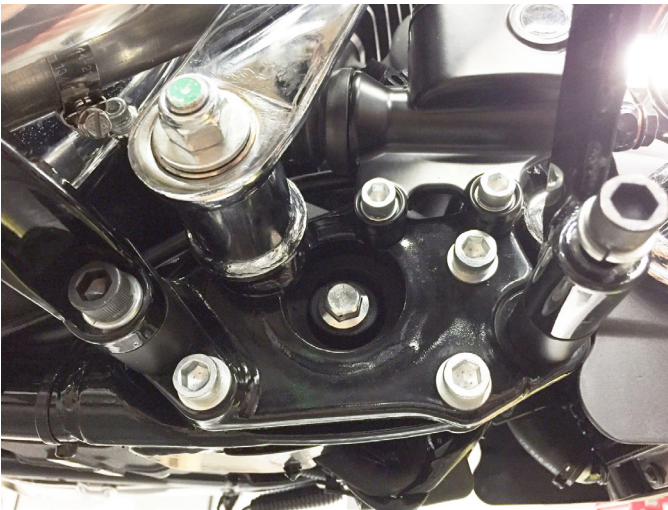
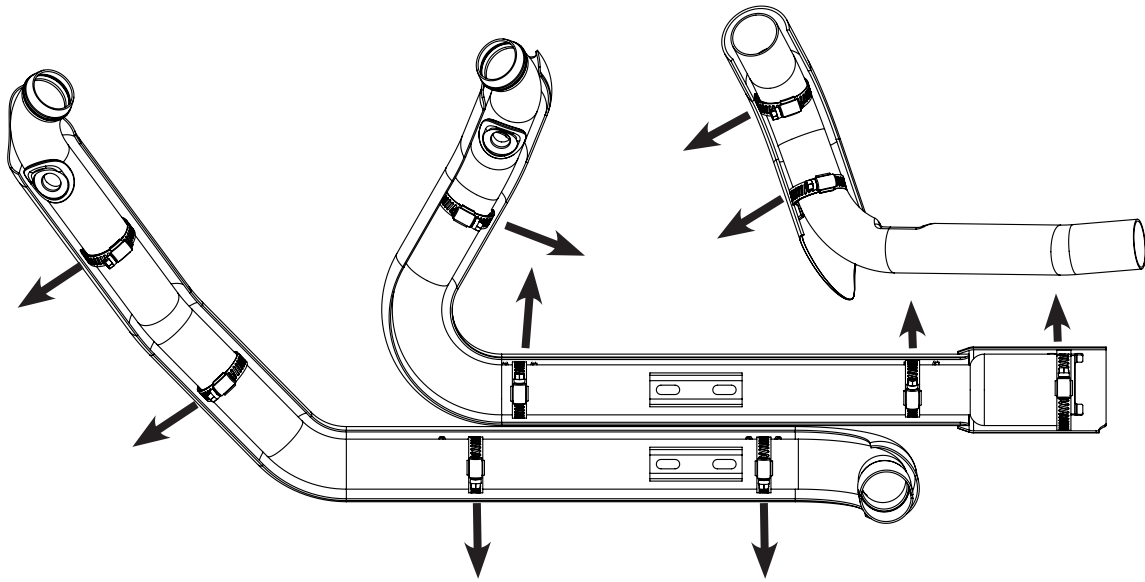

FIGURE 4



Emissions Notice:

In California, in order to meet Air Resources Board emissions requirements, certain aftermarket part applications have been identified as replacements, and others have received ARB Executive Orders. All other emissions related aftermarket parts are for competition use only. A list of replacement parts and EO parts, and corresponding fitment is provided at vanceandhines.com/california.

Warranty:

All Vance & Hines products are warranted against defects in material and workmanship for a period of 90 days. This warranty does not cover discoloration or rust. This warranty shall be limited to the repair or replacement of the product, which may be proven defective under normal use. Vance & Hines will not warranty any system that has been abused, misused, improperly installed or modified.

Dealers or distributors are not authorized to make dispositions binding upon Vance & Hines. Vance & Hines will not be responsible for any labor charges incurred in removing or replacing any system under warranty. A return authorization number and a copy of the original purchase invoice must accompany all returns. Parts returned without a return authorization may be refused.

13861 ROSECRANS AVENUE / SANTA FE SPRINGS, CA 90670
SALES: (562) 921-5388
TECHNICAL: (562) 926-5291
FAX: (562) 802-0110

vanceandhines
.com