

# Kawasaki

## Assembly Instructions

Model:	ZR900C/E
Description:	High Seat
Part Number:	99994-1023
Flat Rate Time(Hr):	0.1

Before you begin, read through these instructions and check that all parts are present. Please note that Kawasaki cannot assume any responsibility for damage resulting from incorrect installation.

Kawasaki recommends that all genuine accessories should be fitted by an authorized Kawasaki dealer.

The following symbols indicate the information for proper installation and operation in this instruction.

- Indicates a procedural step or work to be done.

Refer to the Service Manual (P/No.: 99924-1537-02) for detailed procedures.

Parts List				
No.	Component Name	Part No.	Qty	Remark
1	Seat	53066-0574	1	
2	Damper	92161-2132	2	

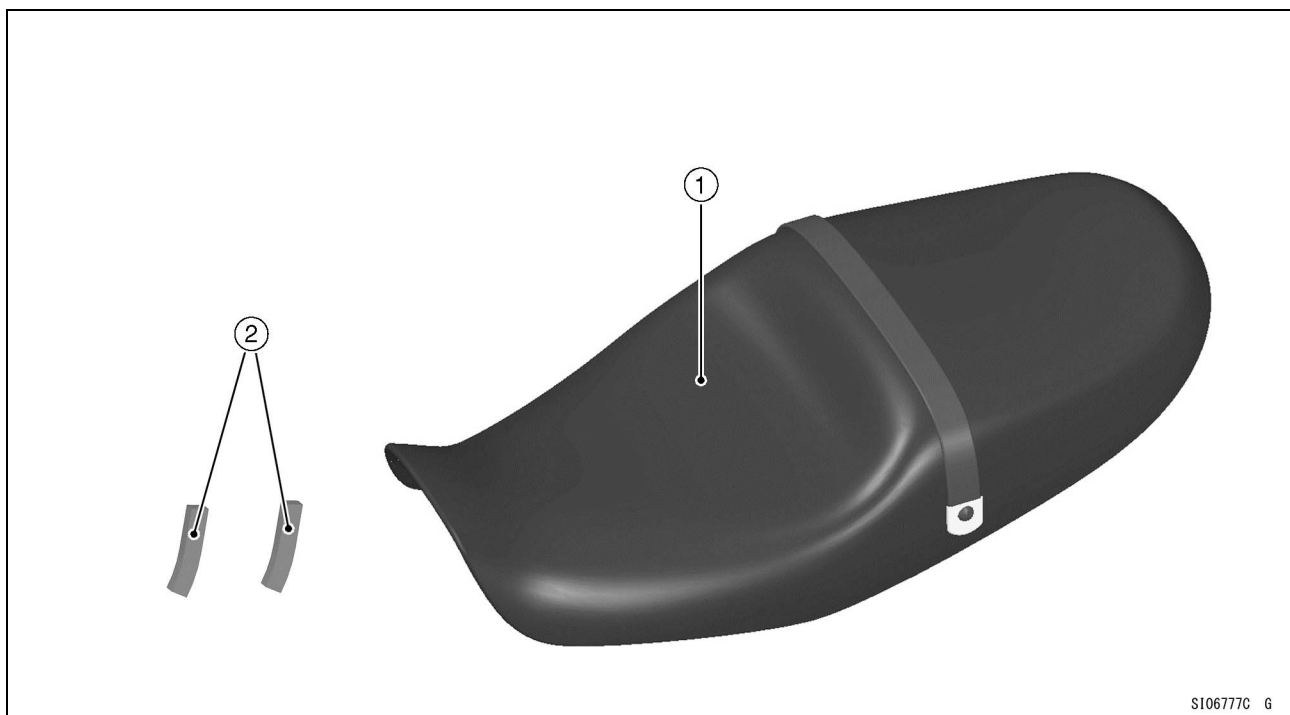

S106777C G

## Installation Instructions

- Remove the seat (Refer to the Service Manual).
- Remove the wing nuts [A], washers and tool kit [B].
- Install the tool kit on the seat [1], and tighten the wing nuts with washers securely.

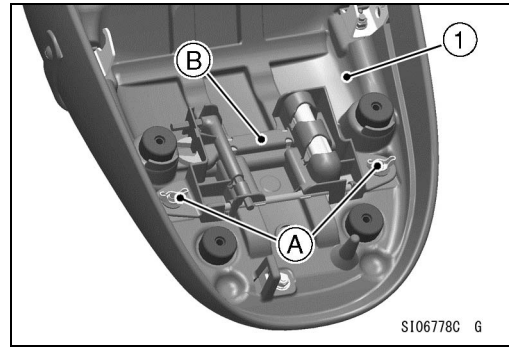

- Using a high flash-point solvent, clean off any dirt that may be on the damper putting surfaces [A] of the seat [1]. Dry them with a clean cloth.

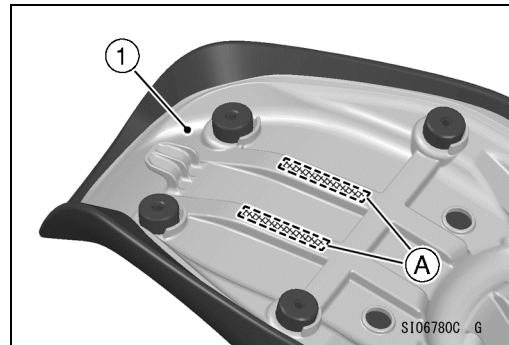

- Peel the release paper in back of the damper [2].
- Align each damper [2] with the scribe line of the seat [1], and put them.
- Install the seat [1] (Refer to the Service Manual).

