



Part No. 2320-0174



MEK2009

REVISION 08042014

Trigger-Lock Mounting Kit - Polished MS Batwing Fairing, Memphis Fats/Slim HD XL1200X Sportster Forty Eight

Aluminum parts are electrocoated (E-coated) for durability and weather resistance.

Before assembly, read Warnings inside



WARNING

1. During installation, make sure that the windshield and hardware do not interfere with any cables or wiring when the forks are turned all the way in either direction. Also make sure, through the full range of adjustment, that the windshield and hardware do not hit the gas tank.
2. This is a detachable windshield, ALWAYS make sure the locking mechanism is fully engaged after installing the windshield.
3. The improper installation of this kit and related components could result in serious injury or death.



CAUTION

1. Memphis Shades windshields are made from Lucite® acrylic, and will last for years with proper care. Clean your windshield with plenty of soapy water (mild dish-washing liquid is best) and a soft cotton cloth. Use your bare hands to feel and dislodge bugs, or cover with a wet, soapy towel and let it soak. Don't use paper towels and scrape with anything. Small scratches can be removed with NOVUS #2.
2. Never use any glass cleaning products, petroleum based chemicals, or cleaning agents with ammonia, bleach or any other harsh chemicals. This includes (but not limited to) RainX, brake fluid, acetone, paint thinner, benzene and gasoline. "If it hurts your nose, it will hurt the plastic."
3. Glass cleansing agents will cause severe damage to your windshield, and will void your warranty. For care and cleaning we recommend using **Memphis Shades All Kleer**, a unique cleaner/polish, bug remover and rain repellent that leaves a super slick surface that makes the next cleaning even easier.
4. At certain times of the day the Sunlight can reflect off the curvature of a windshield and cause extreme heat build-up on motorcycle instruments and instrument panel. Take care when parking. Park facing the sun, place an opaque object over the instruments or adjust the windshield to avoid reflections.

1. Kit Contents

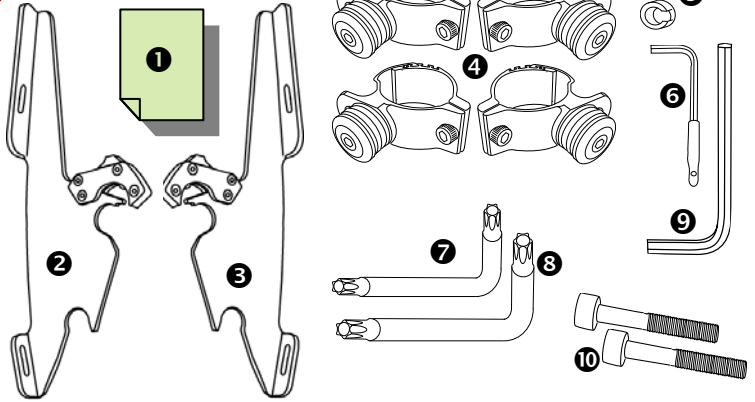

Ref	Code	Description	Qty
1	I2009	Mounting Instructions	1
2	M1137EC	Mounting plate, clutch side	1
3	M1138EC	Mounting plate, throttle side	1
4	S1215EC	Small detachable clamp assembly	4
5	R561EB	Spacer	2
6	M310	Short arm allen wrench, 3/16	1
7	R360	Short arm torx key, T40	1
8	R361	Short arm torx key, T45	1
9	R362	Short arm allen wrench, 5/16	1
10	R363	Socket head cap screw, 3/8-16 x 2	2

2. Mounting Instructions

Additional tools required that are not included in this kit. 7/16 or 11mm wrench.

1. **Cover gas tank and front fender with towels to avoid damage during installation.**
2. Remove the bolt and washer securing the Turn Signal Lamp from the Upper Triple Tree (Fig 1a). Let the Turn Signal Lamp hang by its cable. Refit the bolt into the Upper Triple Tree and tighten. Retain the washer.
WARNING: Remove, Replace and Retighten one bolt at a time to prevent fork tube from slipping in triple clamp!
3. Remove the bolt from the Lower Triple Tree (Fig 1b). Using the bolt provided 10, the washer from step 2, and spacer 5 provided, fit the Turn Signal Lamp into the Lower Triple Tree.
4. Repeat for the other Turn Signal Lamp.

Memphis Shades warrants all product components, metal and plastic, against defects in materials and workmanship for 24 months.

For Parts and Warranty Help, Contact:

Memphis Shades, Inc.
P.O. Box 429
Rossville, TN 38066
(901) 853 0293

Visit us on the web at www.memphisshades.com or you can also reach us by email: customerservice@memphisshades.com

2. Mounting Instructions, continued

5. On the Throttle side, remove the bolt holding the Mirror in place (Fig 2a). Remove the mirror and re-route the throttle cables to the inside. Reinstall the mirror (Fig 2b)

6. Install the two mounting plates **2** and **3** onto the Fairing using the washers and acorn nuts provided (Fig. 3a) Install the two mounting plates **2** and **3** onto the windshield, using the bottom and third bolt up. (Fig. 3b) Leave the nylon washers off. The small tab goes to the bottom, big one at the top. *Tabs point out away from the Headlight.*

7. Loosely install the four Fork Clamps **4** on the forks, approximately 2" apart. (Fig. 4)

8. Slip the windshield mounting plates and windshield onto the fork clamps, (Fig. 5) and secure the left and right side locking mechanism

9. Adjust the height, angle and alignment of the windshield and tighten **ALL** bolts.

Note: This is a detachable windshield, ALWAYS make sure the Locking Mechanism is Fully Engaged after installing the windshield! (Fig. 6)

Fig. 1a

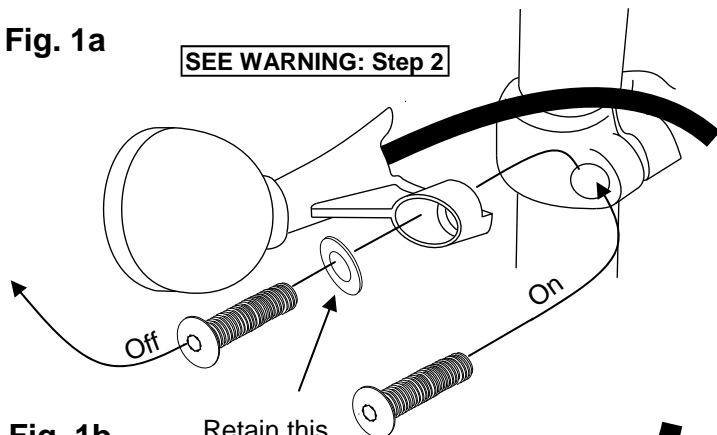

Fig. 1b

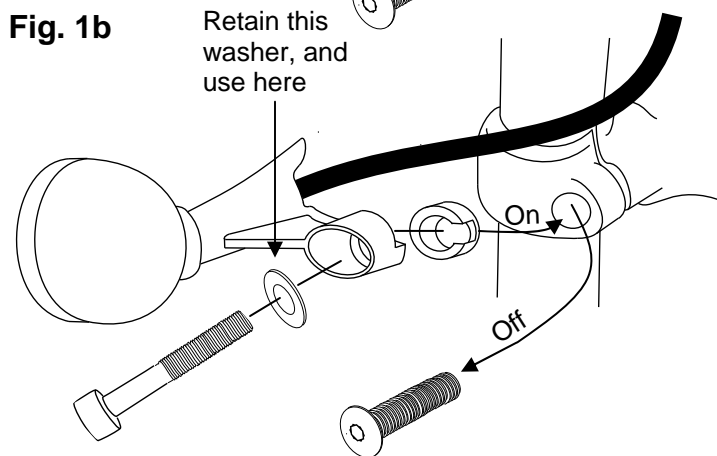

Fig. 2a

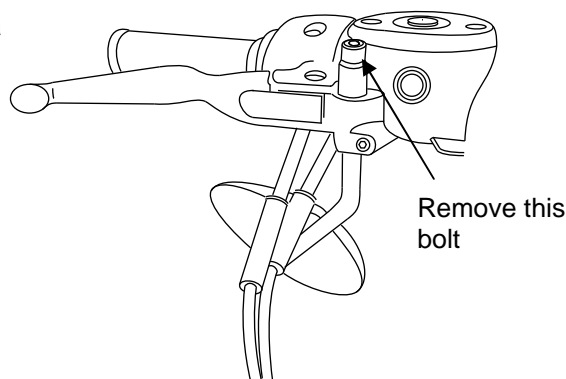

Fig. 2b

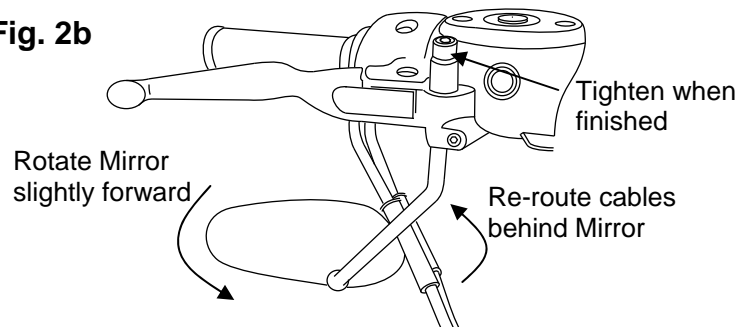

Fig. 3a

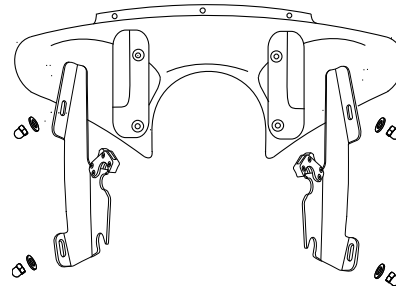

Fig. 3b

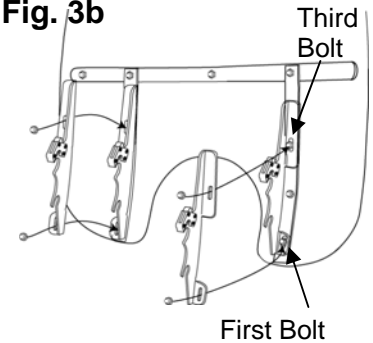

Fig. 4

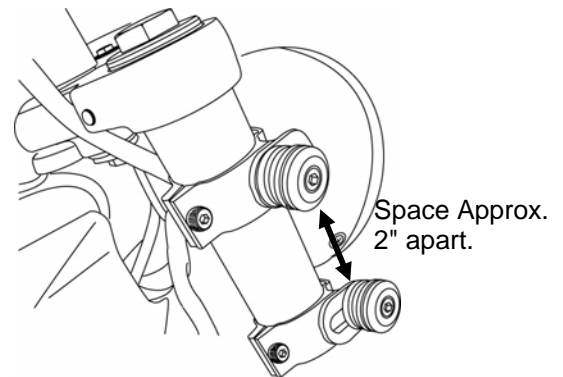
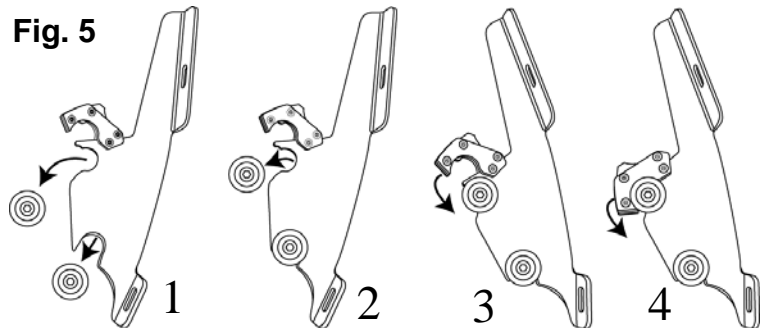

Fig. 5



1. Align the plates with the bushings.
2. Push lower slot into lower bushing.
3. Rotate the plates forward and push the upper slot into the upper bushing.
4. Lock the trigger in place.

Fig. 6

