

Items Supplied >

- | | |
|---|---------------------|
| 1 - RIGHT HEADPIPE W/ HEATSHIELD | 7 - CLAMP, HS-24 |
| 1 - LEFT FRONT HEADPIPE W/ HEATSHIELD | 4 - CLAMP, HS-28 |
| 1 - LEFT REAR HEADPIPE W/ HEATSHIELD | 3 - CLAMP, 27-61MSC |
| 2 - MUFFLERS | 2 - BILLET TIPS |
| 1 - RIGHT MUFFLER HEATSHIELD | 1 - SPACER |
| 1 - LEFT MUFFLER HEATSHIELD | |
| 1 - RIGHT EXHAUST MOUNT BRACKET | |
| 1 - LEFT EXHAUST MOUNT BRACKET | |
| 4 - BOLT, 5/16" X 5/8" FLANGE W/ LOCK PATCH | |
| 4 - BOLT, 3/8" X 3/4" FLANGE W/ LOCK PATCH | |
| 2 - BOLT, 1/4" X 3/8" BUTTON HEAD | |
| 1 - BOLT, 3/8" X 2-1/2" ALLEN HEAD | |

Application(s) >

HARLEY:	
FLST HERITAGE SOFTAIL	2006
FLSTC HERITAGE SOFTAIL CLASSIC	97-06
FLSTF SOFTAIL FAT BOY	97-06
FLSTN SOFTAIL DELUXE	05-06
FLSTS HERITAGE SPRINGER	97-03
FLSTSC SOFTAIL SPRINGER CLASSIC	05-06
FXST SOFTAIL STANDARD	99-06
FXSTB NIGHT TRAIN	99-06
FXSTC SOFTAIL CUSTOM	97-99
FXSTD SOFTAIL DEUCE	00-06
FXSTS SPRINGER SOFTAIL	97-06

Instruction Manual >

6984

Page 1 of 5

PRIOR TO INSTALLATION, MAKE SURE YOUR STOCK HEADPIPE GASKETS ARE IN GOOD CONDITION. IF YOU HAVE ANY DOUBTS AS TO THEIR CONDITION, REPLACE THEM.

Read all instructions carefully and completely before installing your new exhaust system!

1. Apply masking tape to any surrounding parts on the motorcycle to protect them from getting scratched.
2. Remove the stock exhaust system being careful not to damage the headpipe gaskets. If the headpipe gaskets are in good condition they do not need to be removed from the cylinders. Remove and save the flanges, nuts, and retaining rings from the stock exhaust.
3. On FLSTC, FLSTF, and FLSTN, remove the right floorboard. Remove the top and rear bolts for the right floorboard mounting bracket that are behind the rear brake lever. Loosen the front bolt and rotate the mount down out of the way. See **FIGURE 1**. This will make the installation of the exhaust and heatshields easier.

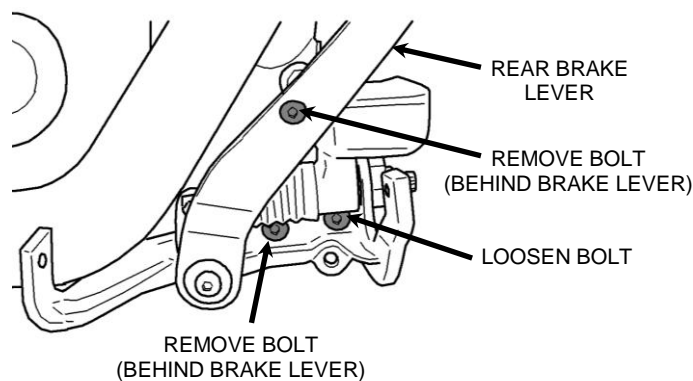

FIGURE 1

4. Remove the right side passenger foot peg from the clevis mount that is attached to the exhaust mount bracket. Remove the clevis mount from the exhaust mount bracket and then the stock exhaust mount bracket from the frame. Install the right side passenger foot peg using the 3/8" x 2-1/2" bolt and the supplied spacer into the rear most hole in the frame. See **FIGURE 2**. Tighten to factory specifications.

Continued on Page 2

*** Cobra® recommends you always wear a helmet while riding. Please never operate your motorcycle while under the influence of alcohol and/or drugs. Enjoy the new look of your motorcycle and please ride safely.**

5. Install the supplied left and right exhaust mount brackets using the supplied 3/8" x 3/4" hex flange bolts. Lift up on the rear of the exhaust mount bracket slightly while tightening the bolts. Tighten the bolts to factory specifications. See **FIGURE 2**.

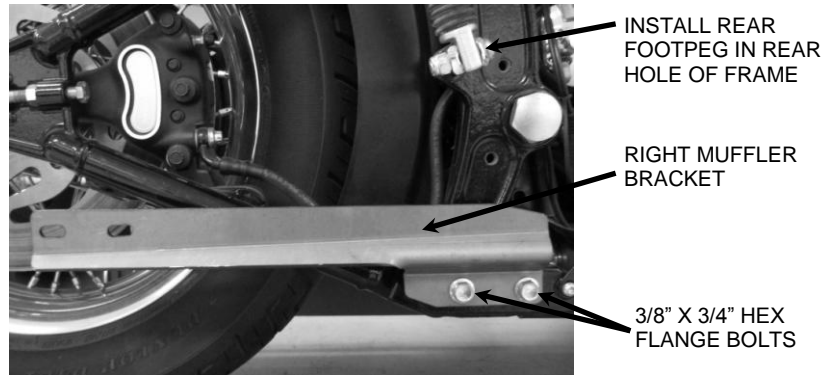

FIGURE 2

6. Install the stock flanges and retaining rings onto the supplied front and rear headpipes.
7. Install the right headpipe (with stock gasket in place) onto the front cylinder using the stock nuts but **DO NOT TIGHTEN** at this time.
8. Install the left front (forward most) headpipe (with stock gasket in place) onto the rear cylinder using the stock nuts. Make sure to align the headpipe properly so that there is the same amount of space between the rear cylinder fins and the coil bracket. Snug the inner rear flange nut first and then snug the outer front flange nut second. **DO NOT TIGHTEN** at this time.
9. Position the supplied #27-61 MSC clamp so that when installed the hex head will be facing down and forward at a 45 degree angle as shown in **FIGURE 3** and slide onto the left rear headpipe inlet.
10. Slide the left rear headpipe inlet (with clamp) over the left front headpipe outlet. Make sure the left rear headpipe inlet goes onto the left front headpipe outlet as far as possible. Align the clamp with the hex head facing down and forward at a 45 degree angle as shown in **FIGURE 3**. (NOTE: The clamp should be flush with the end of the left rear headpipe inlet when tightened. See **FIGURE 4**. If the clamp is slid past the slots on the headpipe inlet the clamp will not tighten properly). Also, check to make sure the shift linkage does not interfere with the clamp. Snug the clamp but **DO NOT TIGHTEN** at this time.



FIGURE 3

POSITION 27-61 MSC CLAMP WITH HEX HEAD FACING DOWN AND FORWARD AT 45 EGREES

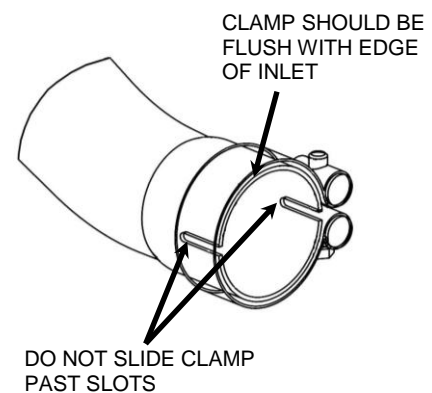
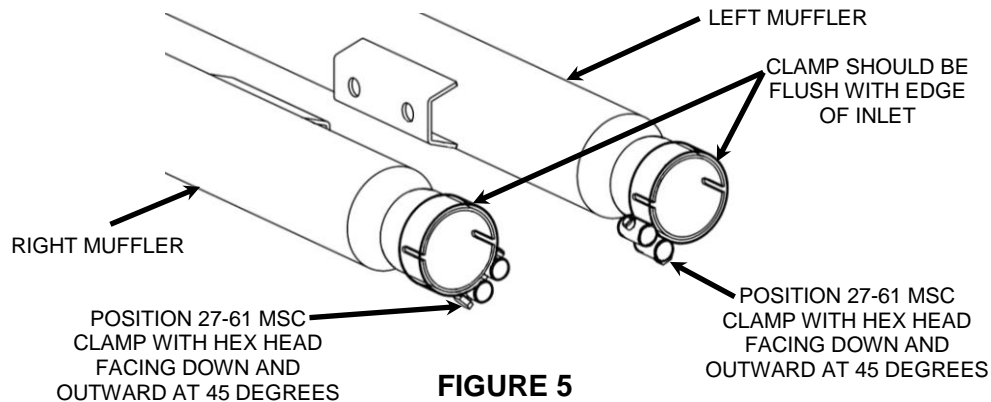

FIGURE 4

Continued on Page 3

11. Position the supplied #27-61 MSC muffler clamp with hex head facing down and outward at a 45 degree angle as shown in **FIGURE 5** and slide onto the left and right rear muffler inlet tubes. (NOTE: The clamps should be flush with the end of the muffler inlets when tightened. See **FIGURE 5**. If the clamps are slid past the slots on the muffler inlets the clamps will not tighten properly).



12. Slide the right muffler on to the right headpipe and secure to the right exhaust mount bracket using the supplied 5/16" x 5/8" hex flange bolts. Make sure the muffler goes onto the headpipe as far as possible. Snug the clamp first and the bolts second but **DO NOT TIGHTEN** at this time.
13. Install the left muffler in the same way onto the left headpipe. Make sure the muffler goes onto the headpipe as far as possible. Snug the clamp first and the bolts second but **DO NOT TIGHTEN** at this time.
14. Make sure the left and right headpipes and mufflers are straight and parallel with the ground. Also make sure the left front and left rear headpipes have the proper clearance between the rear cylinder fins and the coil bracket. From the rear of the motorcycle make sure the muffler outlets are flush and level with each other. When all the pipes are aligned tighten in the following order; headpipe flanges to the cylinders (slowly tightening opposing nuts), mufflers to the exhaust mount bracket, left rear headpipe clamp, and finally the muffler clamps. (NOTE: The muffler clamps should be flush with the end of the muffler inlet when tightened. See **FIGURE 5**. If the muffler clamps are slid past the slots on the muffler inlets the clamps will not tighten properly).
15. Unscrew the **HS-28** and **HS-24** clamps and feed the tail end of the clamp through the clips on the inside of the heatshields. The larger clamps (**HS-28**) go on the muffler heatshields. The smaller clamps (**HS-24**) go to the headpipe heatshields. See **FIGURE 6** and **FIGURE 7** for proper positioning of the clamps on the heatshields. (NOTE: The arrows point to the positioning of the hex head of the clamps. The hex head of the clamps should be accessible for tightening but not visible when heatshields are mounted to the pipes. To help hide the clamps on the muffler heatshields, rotate the clamps so that the hex head is facing down and outward at a 45 degree angle.)
16. Install the right headpipe heatshield first followed by the right muffler heatshield second. See **FIGURE 6**. Slide the rear portion of the muffler heatshield forward over the muffler while gently pushing the front of the muffler heatshield underneath the rear of the right headpipe heatshield. (NOTE: Spread the hose clamps apart slightly to make it easier to slide them over the muffler and headpipes.) Make sure the muffler clamp does not interfere with the heatshield and is aligned as shown in **FIGURE 5**.
17. Slowly snug the heatshield clamps, one by one, while simultaneously aligning the headpipe heatshield to the muffler heatshield. Leave the clamps loose enough to make adjustments to the heatshields positioning as necessary. The ends of the muffler heatshield and headpipe heatshield should be flush with each other. Also be sure to rotate the muffler heatshield around the muffler so that the inner edges of the heatshields are flush. (NOTE: The muffler may have to be adjusted up or down on the mount bracket to align the muffler heatshield with the headpipe heatshield perfectly.)

Continued on Page 4

18. Align the tapped hole in the side of the billet tip with the hole in the muffler heatshield and slide it into the heatshield. (NOTE: If it is difficult to slide the tip into the heatshield loosen the clamps on the muffler heatshield. Failure to do this may cause damage to the tips.) Fasten the tip with the supplied 1/4-20 button head screws making sure there is no gap between the tip and muffler heatshield when tightened.
19. Check to make sure the muffler heatshield is parallel with the headpipe heatshield and that the ends of the heatshields are flush. When the heatshields are aligned properly, tighten the hose clamps. (NOTE: To help hide the clamps on the muffler heatshields, rotate the clamps so that the hex head is facing down and outward at a 45 degree angle.)
20. Install the left front headpipe heatshield. See **FIGURE 6**. Make sure the heatshield has even spacing between the rear cylinder fins and the oil lines. When the heatshield is aligned properly tighten the heatshield clamps.
21. Install the left rear headpipe heatshield, left muffler heatshield, and billet tip the same way as the right heatshields. Make sure they are properly aligned and that the edges of the heatshields are flush. See **FIGURE 7**.



NOTE: Arrows point to the position of the hex head of the clamps.

HS-28 CLAMP RIGHT MUFFLER HEATSHIELD HS-28 CLAMP 27-61MSC CLAMP HS-24 CLAMP RIGHT FRONT HEADPIPE HEATSHIELD HS-24 CLAMP

FIGURE 6

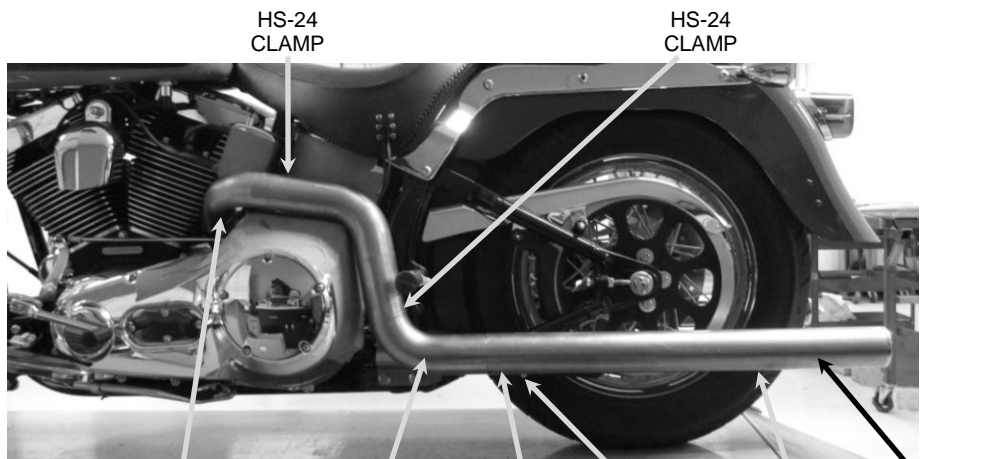

NOTE: Arrows point to the position of the hex head of the clamps.

HS-24 CLAMP LEFT REAR HEADPIPE HEATSHIELD 27-61MSC CLAMP HS-28 CLAMP HS-28 CLAMP LEFT MUFFLER HEATSHIELD

FIGURE 7

Continued on Page 5

22. Rotate the right floor board mount back into position and tighten the bolts to factory specifications.
23. Install the right floorboard back onto the mount.
24. Make sure all the hardware (brackets, headpipes, heatshields, clamps, and tips) has been tightened appropriately.
25. **IMPORTANT: Before starting your engine remove all fingerprints from chrome with a quality wax or chrome polish. Failure to do so can cause chrome discoloration. Due to fluctuations in fuel delivery settings, timing, etc., Cobra Engineering does not warrant against chrome discoloration.**

IMPORTANT: It is recommended that a Cobra Fi2000® Digital Fuel Processor (2001-2005 use Part#: 692-1605AT & 692-1605; CA state models use Part#: 692-1605-50, 2006 use Part#: 692-1604AT & 692-1604; CA state models use Part#: 692-1604-50) be installed with the Cobra exhaust system.

California does not allow the use of aftermarket exhaust systems that remove original equipment catalysts, (except for racing use only) unless the Air Resources Board has issued an Executive Order for that system.